



Submersible Drainage & Sewage Pump 60Hz

Efficient discharge of sewage



No. 3-8, Sanchial Tsun, Lutsao Hsiang, Chiayi County, Taiwan
Tel :+886 5 3750488 Fax:+886 5 3752330
www.stairs.com.tw E-mail:stairs@stairs.com.tw

1120829



STAIRS INDUSTRIAL CO., LTD.



Model Code

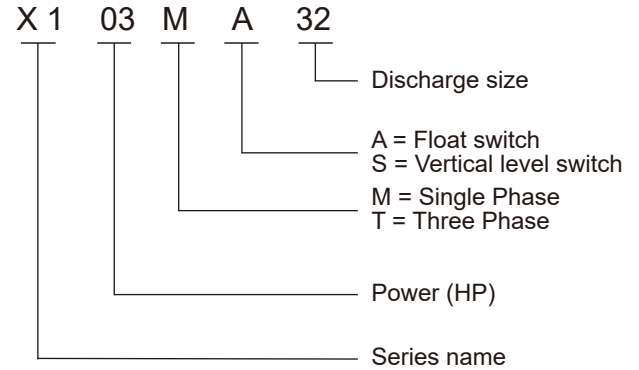

Feature

Compact design with Top Discharge Outlet reduces space usage for installation in small manholes, for use in domestic, installations and small featured works. Two different types of lever sensors :

- Mechanical activated float switch with cable extender (A)
- Vertical Mechanical activated Float Switch with casement (S)

Top discharged cools and removes heat from the motor through the outlet. It allows these pumps to be used even when only partially submerged. Every model undergoes hydrostatic testing for leakage from the casing and mechanical seals.

Applications

- Domestic drainage
- Grey water drainage.
- Koi pond
- Light waste water discharge.
- Hydro-sanitary
- Fountain and landscape
- Drainage pumping.
- Livestocks
- Emergencies flooding pumping

Motor Data

- Motor Type : 2 POLE , dry type
- Frequency : 60Hz
- Nominal Speed : 3450 rpm
- Insulation Class : F class (155°C)

Operation Conditions

- Fluid Temperature: 0 to 50°C (122°F)
- MAX.depth : Maximum 5M

Pump Data

- Enclosure Protection Class : IP 68
- Protection Device : Thermal Protector (Single phase)
- Insulation Class : F class (155°C)
- Bearing : Double sealed with steel cage
- Mechanical seal : unbalance single mechanical seal bath in oil with spring type oil seal

Material

No.	Component	Material
1	Cable	H05RN-F
2	Float switch	Plastic
3	Handle	NY66+G30
4	Motor cover	AISI 304
5	Motor housing	AISI 304
6	Oil Seal	NBR
7	Mechanical seal	Carbon Graphite Ceramic / NBR/ 304
8	Shaft	AISI 410
9	Pump housing	AISI 304
10	Impeller	AISI 304
11	Pump casing	AISI 304
12	Strainer	AISI 304
13	Spring washer	AISI 304
14	Hex Domed Nuts	AISI 304

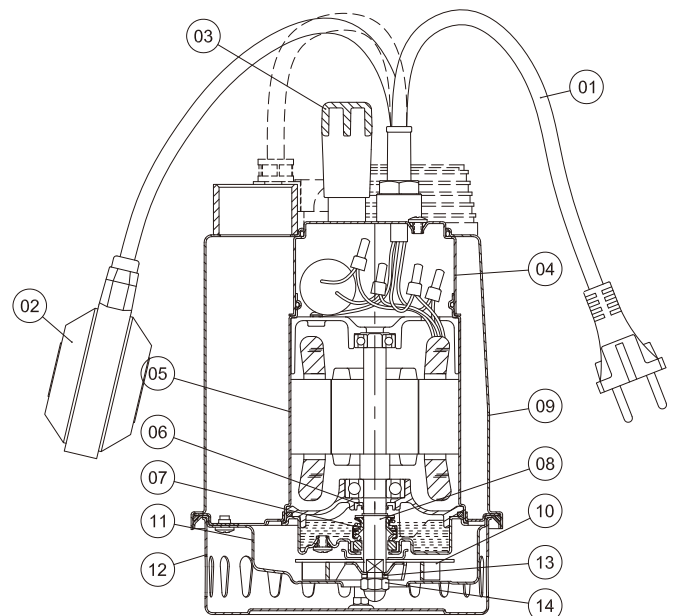

Performance Curves

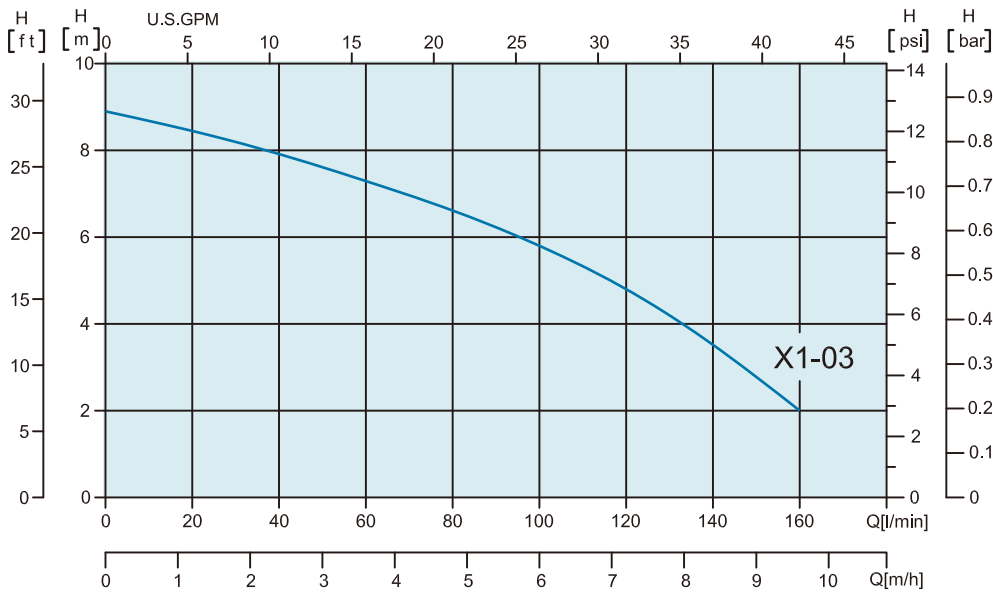

Technical Data

Single Phase

Model	Power		Current(A)		Capacitret		Head		Flow		Discharge inch
	HP	Kw	110-127V	220-230V	110-127V U/F/V	220-230V U/F/V	Rated (M)	Max (M)	Rated (L/min)	Max (L/min)	
X1 03M-32	0.33	0.25	4.6-4.0	2.1-2.0	20UF 250V	6.3UF 450V	6.5	8.7	85	160	1 1/4"
X1 03MA-32											
X1 03MS-32											

Three Phase

Model	Power		Current(A)			Head		Flow		Discharge inch
	HP	Kw	220-230V	380-440V	460-480V	Rated (M)	Max (M)	Rated (L/min)	Max (L/min)	
X1 03T-32	0.33	0.25	1.4-1.3	0.7-0.6	0.6-0.5	6.5	8.7	85	160	1 1/4"

Dimensions

Model	Discharge[mm]		Solid Passage [mm]	Cable		N.W. [kg]
	H	H1		H07 RN-F	M	
X1 03M-32	274	231	10	3G0.75mm ²	10	5.4
X1 03MA-32						5.7
X1 03MS-32						5.8
X1 03T-32	274	231	10	4G0.75mm ²	10	5.4

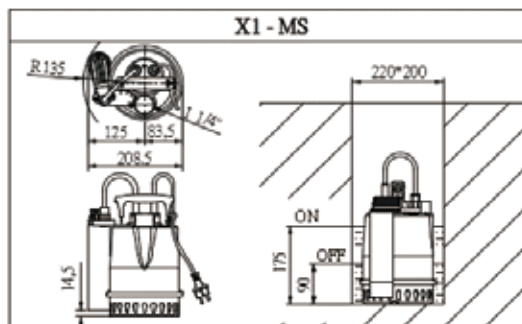
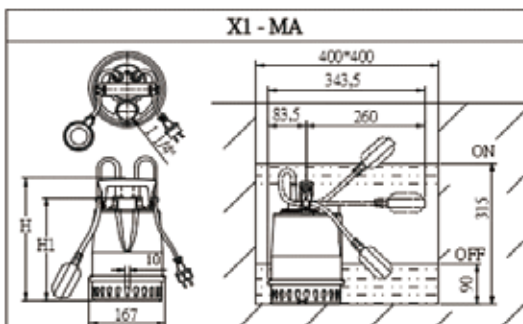



Model Code

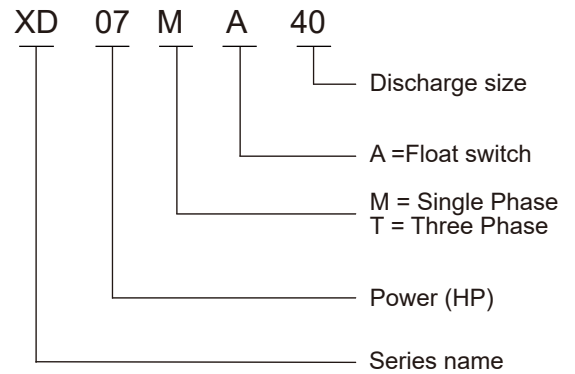

Applications

- Basement water removal
- Waste water drainage
- Water transfer
- Sump/effluent handling
- Dewatering
- Fish pond & fountain circulation
- Factory waste water handling

Motor Data

- Motor Type : 2 POLE , dry type
- Frequency : 60Hz
- Nominal Speed : 3450 rpm
- Insulation Class : F class (155°C)
- Enclosure Protection Class : IP 68
- Protection Device : Thermal Protector (Single phase)

Pump Data

- Impeller : Open Impeller
- Shaft Seal / Mechanical : Double Seals
- Bearing : Double-shielded Ball Bearing

Operation Conditions

- Fluid Temperature: 0 to 50°C (122°F)

Material

No.	Component	Material
1	Cable	H07RN-F
2	Handle	AISI 304+Nylon
3	Pump Cover	AISI 304
4	Motor Cover	AISI 304
5	Motor Casing	AISI 304
6	Fixing Ring	Nylon+30GF
7	Pump body	AISI 304
8	Mechanical seal	Sic /Sic / NBR
9	Impeller	AISI 304
10	Key	AISI 304
11	O-RING	NBR
12	Oil Seal	NBR
13	Shaft	AISI 304
14	V-type Axial Oil Seal	NBR
15	Suction flange	AISI 304
		Thermoplastic polyurethane TPU
16	Strainer	AISI 304

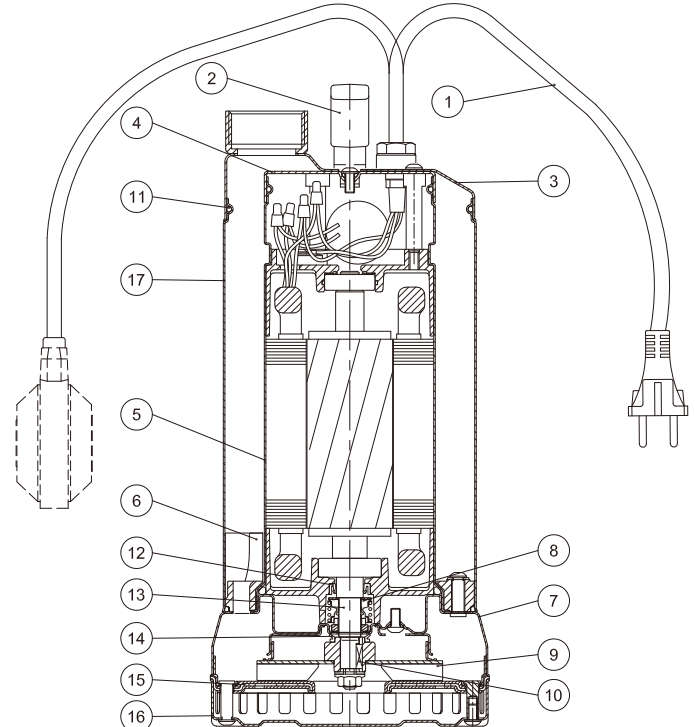

Performance Curves

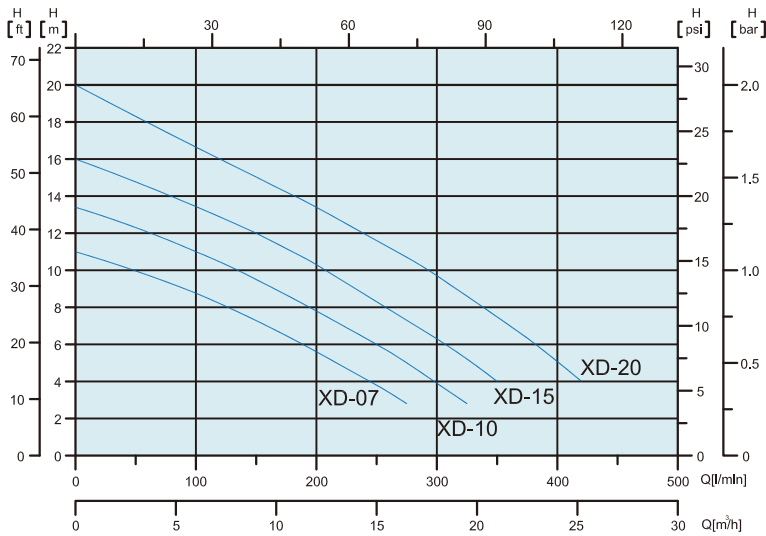

Technical Data

Single Phase

Model	Power		Current(A)		Capacitoret		Head		Flow		Discharge inch
	HP	Kw	110-127V	220-230V	110-127V _{UF / V}	220-230V _{UF / V}	Rated (M)	Max (M)	Rated (L/min)	Max (L/min)	
XD 07-M-40	0.75	0.55	8.8-8.0	4.7-4.5	20UF 350V	20UF 450V	8.7	11.0	100	275	1 1/2"
XD 07-MA-40											
XD 10-M-40	1.0	0.75	11.0-10.3	5.7-5.5	35UF 350V	22UF 450V	11.0	13.4	100	325	
XD 10-MA-40											
XD 15-M-40	1.5	1.1	-	8.0-7.7	-	30UF 450V	12.0	16.0	150	350	
XD 15-MA-40											

A = Auto Float Switch

Three Phase

Model	Power		Current(A)			Head		Flow		Discharge inch
	HP	Kw	220-230V	380-440V	460-480V	Rated (M)	Max (M)	Rated (L/min)	Max (L/min)	
XD 07-T-40	0.75	0.55	2.4-2.3	1.4-1.3	1.2-1.0	8.7	11.0	100	275	1 1/2"
XD 10-T-40	1.0	0.75	3.6-3.5	2.1-2.0	1.8-1.6	11.0	13.4	100	325	
XD 15-T-40	1.5	1.0	4.1-4.0	2.4-2.3	2.3-2.1	12.0	16.0	150	350	
XD 20-T-40	2.0	1.5	5.7-5.5	3.3-3.1	3.0-2.7	15.0	20.0	150	420	

Dimensions

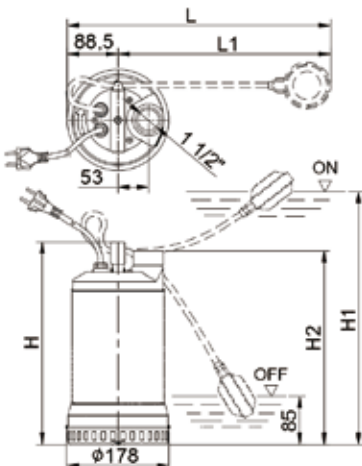

Model	Discharge[mm]					Solid Passage [mm]	Cable		N.W. [kg]
	H	H1	H2	L	L1		H07 RN-F	M	
XD 07-M-40	357	437	341	459	370	8	3G1.0mm ²	10	11.0
XD 07-MA-40	357	437	341	459	370	8	3G1.0mm ²	10	11.5
XD 10-M-40	407	497	391	514	425	8	3G1.0mm ²	10	14.0
XD 10-MA-40	407	497	391	514	425	8	3G1.0mm ²	10	14.5
XD 15-M-40	407	497	391	514	425	8	3G1.5mm ²	10	16.0
XD 15-MA-40	407	497	391	514	425	8	3G1.5mm ²	10	16.5
XD 07-T-40	357	-	341	-	-	8	4G1.0mm ²	10	11.0
XD 10-T-40	357	-	341	-	-	8	4G1.0mm ²	10	12.0
XD 15-T-40	407	-	391	-	-	8	4G1.0mm ²	10	14.0
XD 20-T-40	407	-	391	-	-	8	4G1.5mm ²	10	16.0



Model code

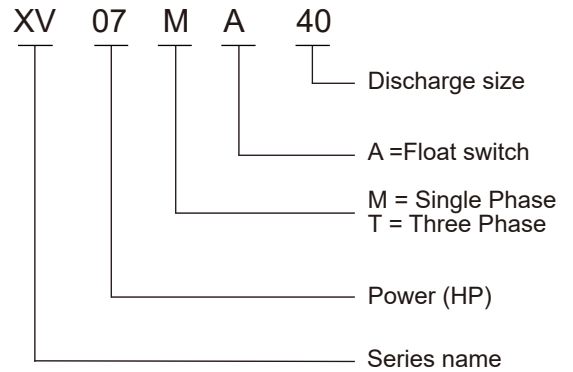

Applications

- Basement water removal
- Waste water drainage
- Water transfer
- Sump/effluent handling
- Dewatering
- Fish pond & fountain circulation
- Factory waste water handling

Motor Data

- Motor Type : 2 POLE , dry type
- Frequency : 60Hz
- Nominal Speed : 3450 rpm
- Insulation Class : F class (155°C)
- Enclosure Protection Class : IP 68
- Protection Device :
Thermal Protector (Single phase)

Pump Data

- Impeller : Open Impeller
- Shaft Seal / Mechanical :
Double Seals
- Bearing :
Double-shielded Ball Bearing

Operation Conditions

- Fluid Temperature: 0 to 35°C (95°F)

Material

No.	Component	Material
1	Cable	H07RN-F
2	Handle	AISI 304+Nylon
3	Motor Cover	AISI 304
4	Motor Casing	AISI 304
5	Fixing Ring	AISI 304
6	Pump Casing	AISI 304
7	Mechanical seal	Sic /Sic / NBR
8	Impeller	AISI 304
9	Key	AISI 304
10	Support Foot	AISI 304
11	Oil Seal	NBR
12	Shaft	AISI 304
13	V-type Axial Oil Seal	NBR
14	Suction flange	AISI 304

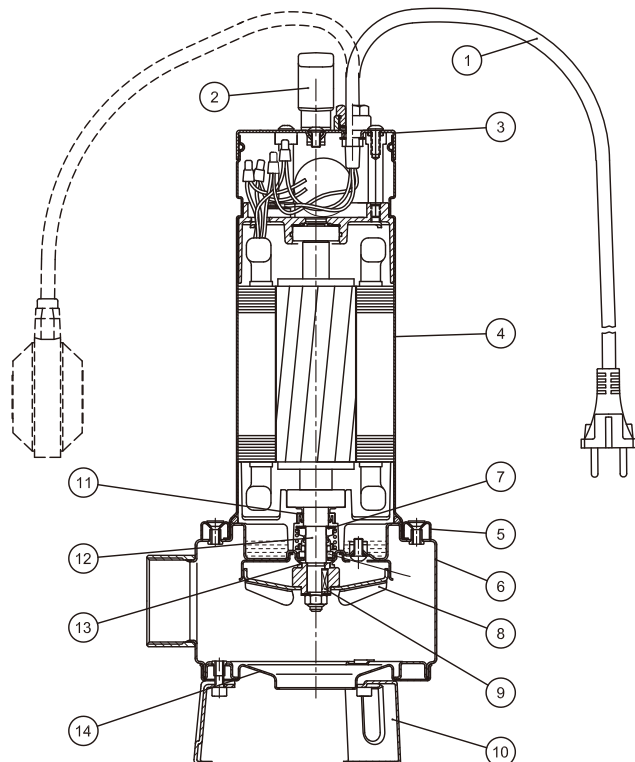

Performance Curves

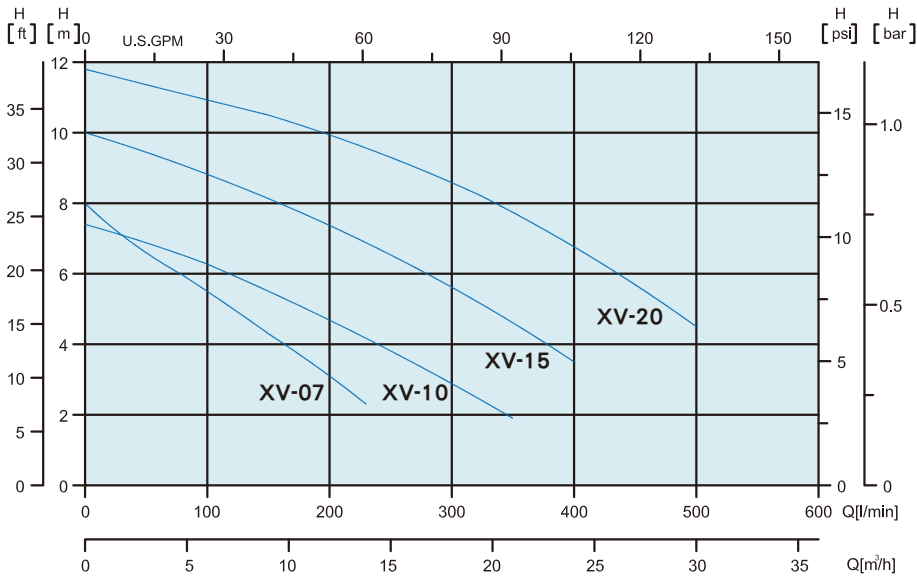

Technical Data

Single Phase

Model	Power		Current(A)		Capacitoret		Head		Flow		Discharge inch
	HP	Kw	110-127V	220-230V	110-127V _{UF/V}	220-230V _{UF/V}	Rated (M)	Max (M)	Rated (L/min)	Max (L/min)	
XV 07-M-40	0.75	0.55	8.8-8.0	4.5-4.3	20UF 350V	20UF 450V	5.9	8.0	80	230	1 1/2"
XV 07-MA-40											
XV 10-M-50	1.0	0.75	11.0-10.3	5.5-5.3	35UF 350V	22UF 450V	6.3	7.4	100	350	2"
XV 10-MA-50											
XV 15-M-50	1.5	1.1	-	8.0-7.7	-	30UF 450V	8.8	10.0	100	400	
XV 15-MA-50											

A = Auto Float Switch

Three Phase

Model	Power		Current(A)			Head		Flow		Discharge inch
	HP	Kw	220-230V	380-440V	460-480V	Rated (M)	Max (M)	Rated (L/min)	Max (L/min)	
XV 07-T-40	0.75	0.55	2.8-2.6	1.5-1.3	1.2-1.0	5.9	8.0	80	230	1 1/2"
XV 10-T-50	1.0	0.75	4.3-4.1	2.5-2.4	1.8-1.6	6.3	7.4	100	350	2"
XV 15-T-50	1.5	1	5.0-4.8	2.9-2.8	2.3-2.1	8.8	10.0	100	400	
XV 20-T-50	2.0	1.5	6.2-5.9	3.6-3.4	2.9-2.7	10.5	11.8	150	500	

Dimensions

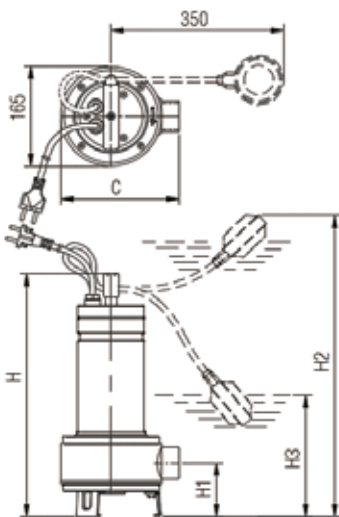

Model	Discharge[mm]					Solid Passage [mm]	Cable		N.W. [kg]
	H	H1	H2	H3	C		H07 RN-F	M	
XV 07-M-40	403	88.0	483	185	193	35	3G1.0mm ²	5	11.0
XV 07-MA-40	403	88.0	483	185	193	50	3G1.0mm ²	10	11.5
XV 10-M-50	486	111.5	566	268	198	50	3G1.0mm ²	10	14.0
XV 10-MA-50	486	111.5	566	268	198	50	3G1.0mm ²	10	14.5
XV 15-M-50	486	111.5	566	268	198	50	3G1.5mm ²	10	16.0
XV 15-MA-50	486	111.5	566	268	198	50	3G1.5mm ²	10	16.5
XV 07-T-50	403	88.0	-	-	193	35	4G1.0mm ²	5	11.0
XV 10-T-50	436	111.5	-	-	198	50	4G1.0mm ²	10	12.0
XV 15-T-50	486	111.5	-	-	198	50	4G1.0mm ²	10	14.0
XV 20-T-50	486	111.5	-	-	198	50	4G1.5mm ²	10	16.0



Model Code

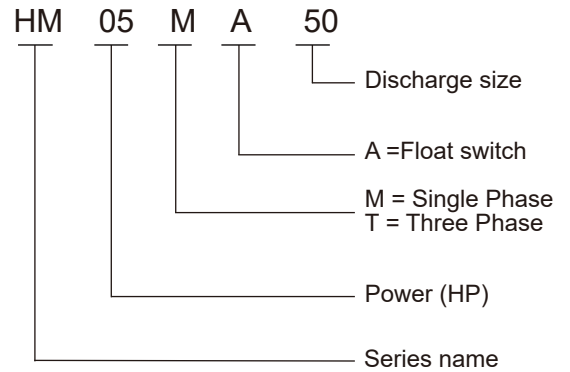

Applications

- Basement water removal
- Waste water drainage
- Water transfer
- Sump/effluent handling
- Dewatering
- Fish pond & fountain circulation
- Factory waste water handling

Motor Data

- Motor Type : 2 POLE , dry type
- Frequency : 60Hz
- Nominal Speed : 3450 rpm
- Insulation Class : F class (155°C)
- Enclosure Protection Class : IP 68
- Protection Device :
Thermal Protector (Single phase)
Overload Protector(Three phase)

Pump Data

- Impeller : Open Impeller
- Shaft Seal / Mechanical :
Double Seals
- Bearing :
Double-shielded Ball Bearing

Operation Conditions

- Fluid Temperature: 0 to 40°C (104°F)

Material

No.	Component	Material
1	Cable	H07RN-F
2	Handle	Nylon6+30GF
3	Motor cover	ADC-12
4	Bearing cap	SECC
5	Motor frame	ADC-12
6	M.Seal Bracket	FC200
7	Cable Base	Nylon6+30GF
8	Motor Shaft	AISI410
9	Mechanical seal	CA / CE, SIC/SIC
10	Oil Seal	NBR70
11	Impeller	TPU
12	Pump casing	FC200
13	Flange	FC200

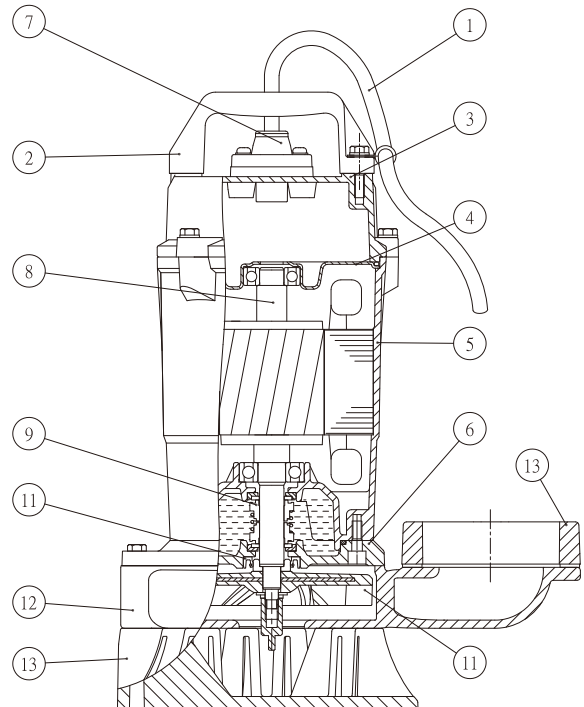

Performance Curves

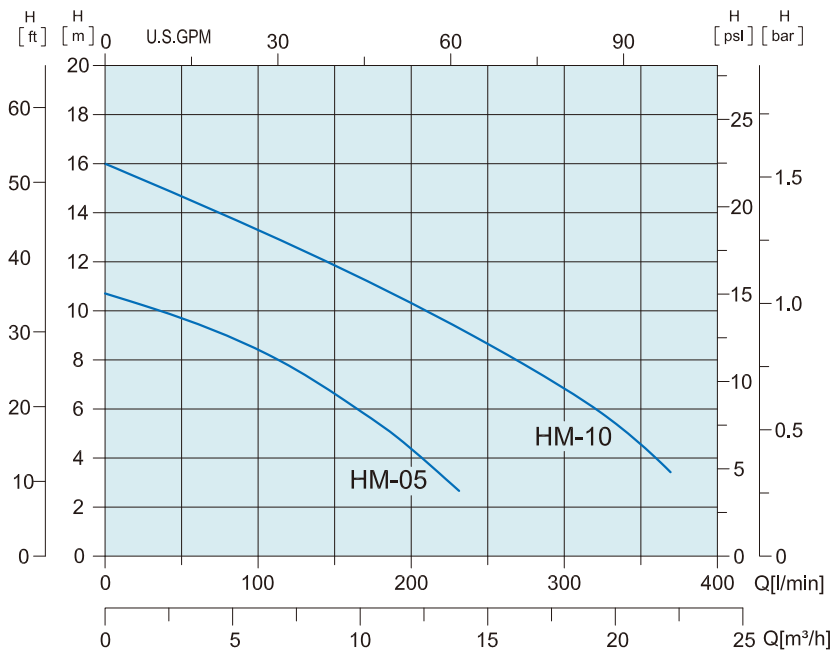

Technical Data

Single Phase

Model	Power		Current(A)		Capacitoret		Head		Flow		Discharge inch
	HP	Kw	110-127V	220-230V	110-127V UF / V	220-230V UF / V	Rated (M)	Max (M)	Rated (L/min)	Max (L/min)	
HM 05-M-50	0.5	0.37	5.6-4.9	2.6-2.5	50uF 250V	12uF 450V	7.0	11.9	140	230	2"
HM 05-MA-50											
HM 10-M-50	1.0	0.75	10.8-9.4	5.4-5.2	80uF 250V	20uF 450V	10.0	17.2	190	316	2"
HM 10-MA-50											
HM 10-M-80	1.0	0.75	10.8-9.4	5.4-5.2	80uF 250V	20uF 450V	10.0	17.2	190	316	3"
HM 10-MA-80											

Three Phase

Model	Power		Current(A)			Head		Flow		Discharge inch
	HP	Kw	220-230V	380-440V	460-480V	Rated (M)	Max (M)	Rated (L/min)	Max (L/min)	
HM 05-T-50	0.5	0.37	2.1-2.0	1.2-1.1	1.2-1.0	7.0	11.9	140	230	2"
HM 10-T-50	1.0	0.75	3.3-3.2	1.9-1.8	1.8-1.6	10.0	17.2	190	316	2"
HM 10-T-80	1.0	0.75	3.3-3.2	1.9-1.8	1.8-1.6	10.0	17.2	190	316	3"

Dimensions

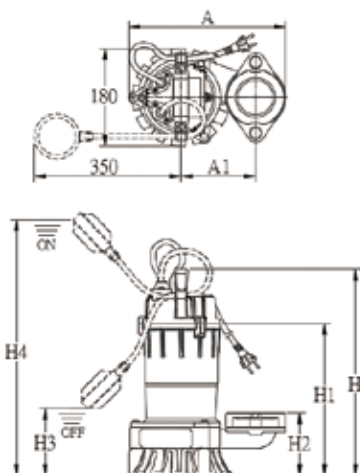

Model	Discharge[mm]							Solid Passage [mm]	Cable		N.W. [kg]
	H	H1	H2	H3	H4	A	A1		M	H07 RN-F	
HM 05-M-50	365	264	110	115	535	254	120	10	10	3G1.0mm ²	12.9
HM 05-MA-50	365	264	110	115	535	254	120	10	10	3G1.0mm ²	13.4
HM 10-M-50	380	279	116	130	550	285	135	10	10	3G1.0mm ²	15.1
HM 10-MA-50	380	279	116	130	550	285	135	10	10	3G1.0mm ²	15.6
HM 10-M-80	380	279	116	130	550	285	135	10	10	3G1.0mm ²	15.1
HM 10-MA-80	380	279	116	130	550	285	135	10	10	3G1.0mm ²	15.6
HM 05-T-50	365	264	110	-	-	254	120	10	10	4G1.0mm ²	11.9
HM 10-T-50	380	279	116	-	-	285	135	10	10	4G1.0mm ²	14.1
HM 10-T-80	380	279	116	-	-	285	135	10	10	4G1.0mm ²	14.1



Model Code

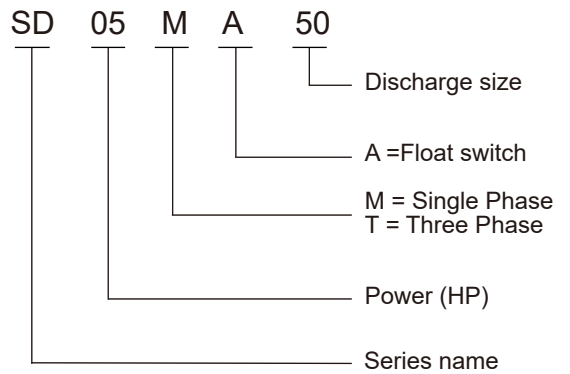

Applications

- Basement water removal
- Waste water drainage
- Water transfer
- Sump/effluent handling
- Dewatering
- Fish pond & fountain circulation
- Factory waste water handling

Motor Data

- Motor Type : 2 POLE , dry type
- Frequency : 60Hz
- Nominal Speed : 3450 rpm
- Insulation Class : F class (155°C)
- Enclosure Protection Class : IP 68
- Protection Device :
Thermal Protector (Single phase)
Overload Protector(Three phase)

Pump Data

- Impeller : Open Impeller
- Shaft Seal / Mechanical :
Double Seals
- Bearing :
Double-shielded Ball Bearing

Operation Conditions

- Fluid Temperature: 0 to 40°C (104°F)

Material

NO.	Component	Material
1	Cable	H07RN-F
2	Handle	Nylon6+30GF(0.5~1.0HP) AISI304+NBR(2.0~5.0HP) SS41(7.5HP)
3	Motor cover	FC200
4	Bearing cap	FC200
5	Motor frame	AISI 304
6	Bearing Bracket	FC200
7	M.Seal Bracket	FC200
8	Cable Base	Nylon6+30GF
9	Motor Shaft	AISI410
10	Mechanical seal	CA/CE,SIC/SIC
11	Oil Seal	NBR 70
12	Impeller	FC25
13	Pump Casing	FC200
14	Flange	FC200
15	Strainer	AISI 304

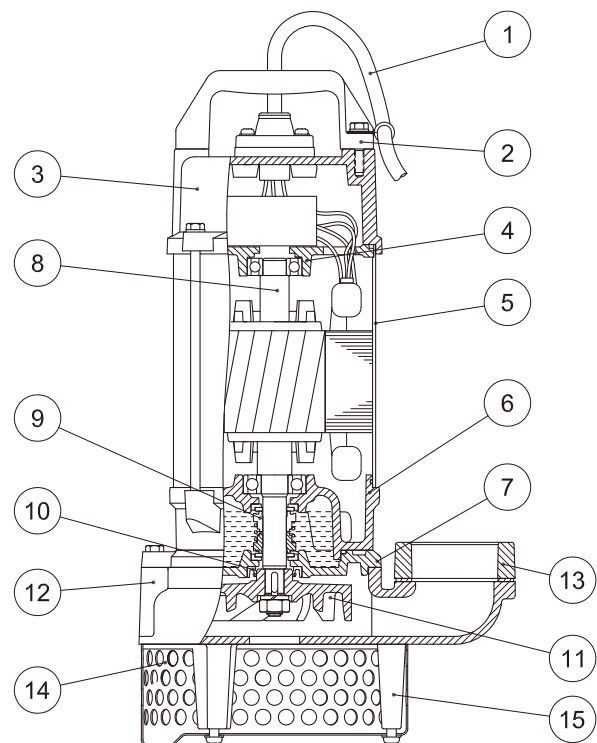

Performance Curves

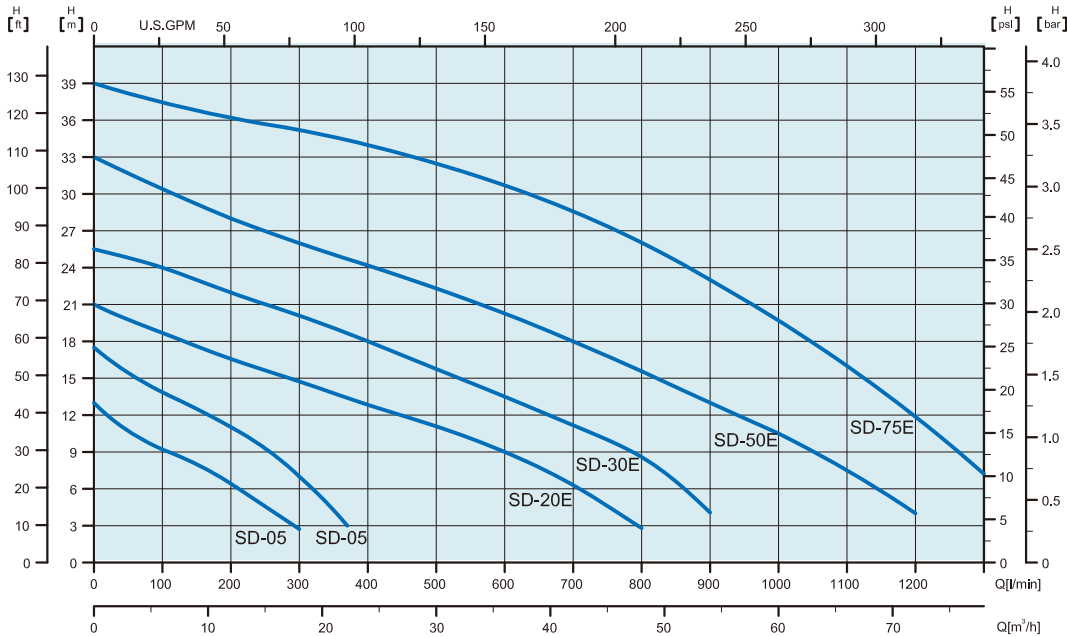

Technical Data

Single Phase

Model	Power		Current(A)		Capacitoret		Head		Flow		Discharge inch
	HP	Kw	110-127V	220-230V	110-127V U F / V	220-230V UF / V	Rated (M)	Max (M)	Rated (L/min)	Max (L/min)	
SD 05-M-50	0.5	0.37	6.6-5.7	3.3-3.1	50uF 250V	12uF 450V	7.5	13.0	170	300	2"
SD 05-MA-50											
SD 10-M-50	1.0	0.75	10.6-9.2	5.3-4.9	80uF 250V	20uF 450V	11.0	17.5	210	370	2"
SD 10-MA-50											
SD 20E-M-50	2.0	1.5	-	10.0-9.2	-	40UF 450V	11.5	21.0	480	800	2"
SD 20E-MA-50											
SD 20E-M-80	2.0	1.5	-	10.0-9.2	-	40UF 450V	11.5	21.0	480	800	3"
SD 20E-MA-80											

A = Auto Float Switch

Three Phase

Model	Power		Current(A)			Head		Flow		Discharge inch
	HP	Kw	220-230V	380-440V	460-480V	Rated (M)	Max (M)	Rated (L/min)	Max (L/min)	
SD 05-T-50	0.5	0.37	2.3-2.2	1.3-1.2	1.3-1.2	7.5	13.0	175	300	2"
SD 10-T-50	1.0	0.5	3.4-3.3	2.1-2.0	1.9-1.7	11.0	17.5	230	370	2"
SD 20E-T-50	2.0	1.5	6.3-6.0	3.6-3.4	3.2-3.0	11.5	21.0	475	810	2"
SD 20E-T-80	2.0	1.5	6.3-6.0	3.6-3.4	3.2-3.0	11.5	21.0	475	810	3"
SD 30E-T-50	3.0	2.2	8.8-8.5	5.0-4.8	4.8-4.7	14.0	25.7	580	940	2"
SD 30E-T-80	3.0	2.2	8.8-8.5	5.0-4.8	4.8-4.7	14.0	25.7	580	940	3"
SD 50E-T-80	5.0	3.7	13.6-13.0	8.0-7.8	7.5-7.3	21.0	33.2	590	1215	3"
SD 50E-T-100	5.0	3.7	13.6-13.0	8.0-7.8	7.5-7.3	21.0	33.2	590	1215	4"
SD 75E-T-80	7.5	5.5	20.0-18.5	12.0-11.0	10.5-9.5	29.0	39.0	680	1300	3"
SD 75E-T-100	7.5	5.5	20.0-18.5	12.0-11.0	10.5-9.5	29.0	39.0	680	1300	4"

Dimensions

Model	Discharge[mm]								Solid Passage [mm]	Cable-10M H07 RN-F	N.W. [kg]
	H	H1	H2	H3	A	B	C	D			
SD 05-M-50	411	356	114	130	240	201	–	173	10	3G1.0mm ²	16.0
SD 05-MA-50	411	356	114	130	240	201	–	173	10	3G1.0mm ²	16.5
SD 10-M-50	431	376	114	130	240	201	–	173	10	3G1.0mm ²	18.0
SD 10-MA-50	431	376	114	130	240	201	–	173	10	3G1.0mm ²	18.5
SD 20E-M-50	546	480	133	227	398	343	253	220	10	3G1.5mm ²	42.5
SD 20E-MA-50	546	480	133	227	398	343	253	220	10	3G1.5mm ²	43.0
SD 20E-M-80	546	480	133	227	398	343	253	220	10	3G1.5mm ²	42.5
SD 20E-MA-80	546	480	133	227	398	343	253	220	10	3G1.5mm ²	43.0
SD 05-T-50	411	356	114	130	240	201	–	173	10	4G1.0mm ²	15.0
SD 10-T-50	431	376	114	130	240	201	–	173	10	4G1.0mm ²	17.0
SD 20E-T-50	506	441	133	227	398	343	255	220	10	4G1.5mm ²	36.0
SD 20E-T-80	506	441	133	227	398	343	255	220	10	4G1.5mm ²	36.0
SD 30E-T-50	506	441	133	227	398	343	255	220	10	4G1.5mm ²	38.5
SD 30E-T-80	506	441	133	227	398	343	255	220	10	4G1.5mm ²	38.5
SD 50E-T-80	526	461	133	265	430	337	255	220	10	4G2.5mm ²	45.0
SD 50E-T-100	526	461	133	265	430	337	255	220	10	4G2.5mm ²	45.0
SD 75E-T-80	658	553	133	265	474	380	294	230	10	4G2.5mm ²	61.0
SD 75E-T-100	658	553	133	265	474	380	294	230	10	4G2.5mm ²	61.0

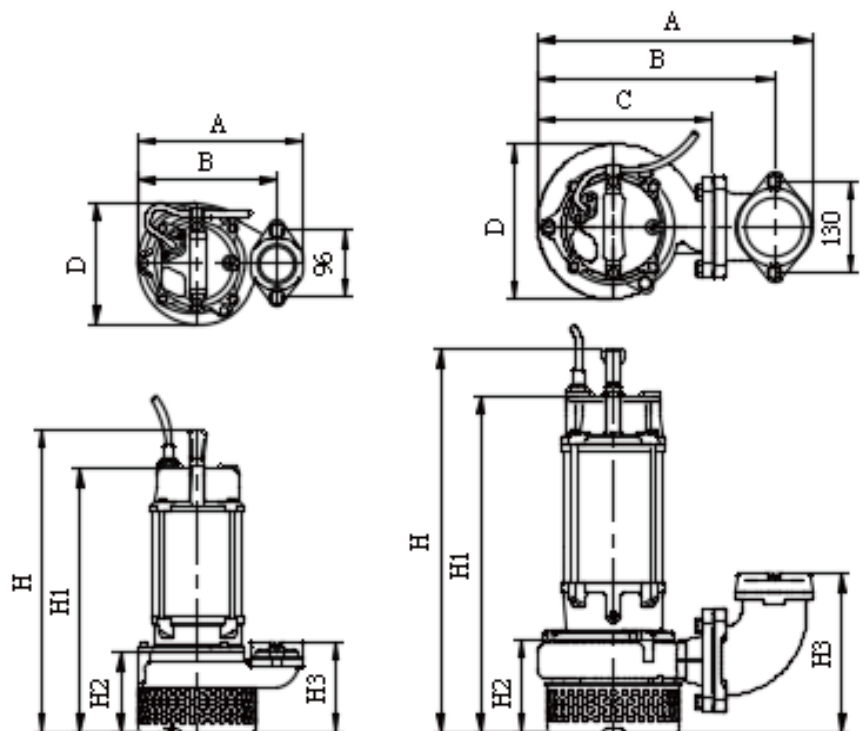



Model Code

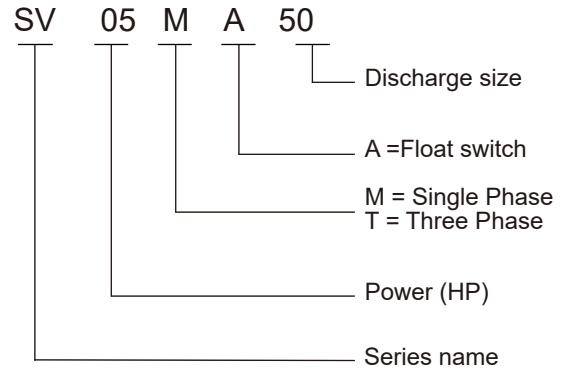

Applications

- Basement water removal
- Waste water drainage
- Water transfer
- Sump/effluent handling
- Dewatering
- Fish pond & fountain circulation
- Factory waste water handling

Motor Data

- Motor Type : 2 POLE , dry type
- Frequency : 60Hz
- Nominal Speed : 3450 rpm
- Insulation Class : F class (155°C)
- Enclosure Protection Class : IP 68
- Protection Device : Thermal Protector (Single phase) Overload Protector(Three phase)

Pump Data

- Impeller : Open Impeller
- Shaft Seal / Mechanical : Double Seals
- Bearing : Double-shielded Ball Bearing

Operation Conditions

- Fluid Temperature: 0 to 40°C (104°F)

Material

NO.	Component	Material
1	Cable	H07RN-F
2	Handle	Nylon6+30GF(0.5~1.0HP) AISI304+NBR(2.0~5.0HP) SS41(7.5HP)
3	Motor cover	FC200
4	Bearing cap	FC200
5	Motor frame	AISI 304
6	Bearing Bracket	FC200
7	M.Seal Bracket	FC200
8	Motor Shaft	AISI410
9	Mechanical seal	CA / CE, SIC/SIC
10	Oil Seal	NBR70
11	Impeller	FC250
12	Pump casing	FC200
13	Flange	FC200

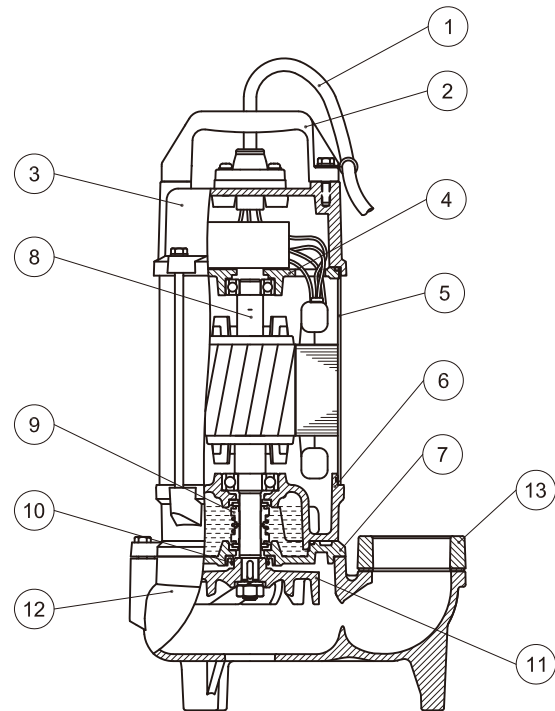

Submersible Vortex Sewage Pumps

60Hz

Performance Curves

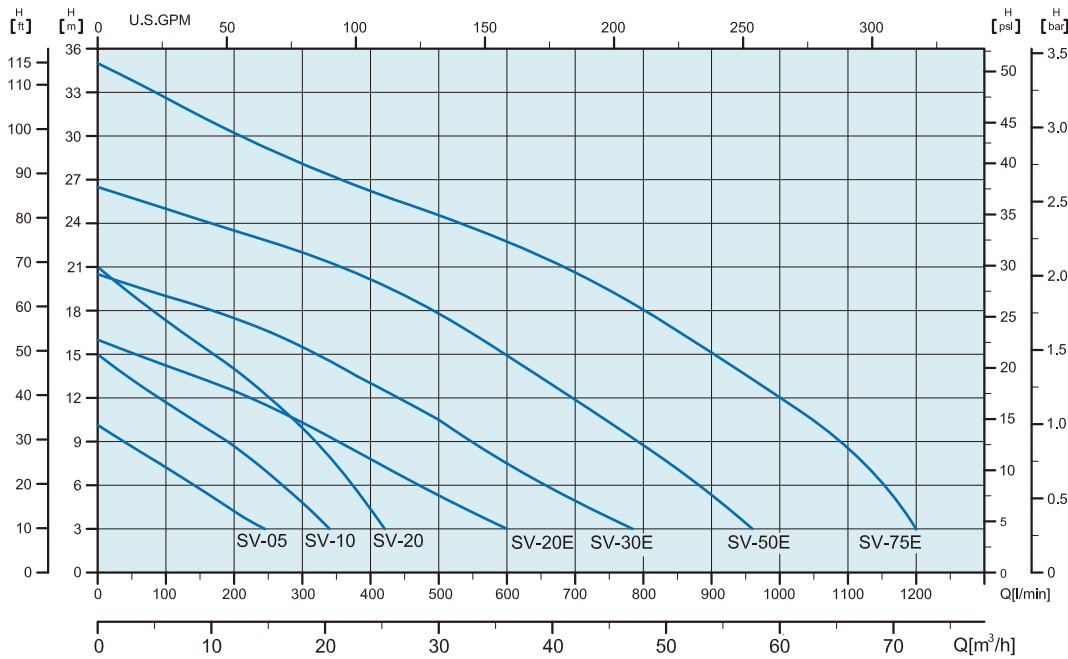

Technical Data

Single Phase

Model	Power		Current(A)		Capacitoret		Head		Flow		Discharge inch
	Single Phase	HP	Kw	110-127V	220-230V	110-127V UF / V	220-230V UF / V	Rated (M)	Max (M)	Rated (L/min)	
SV 05-M-50	0.5	0.37	6.6-5.7	3.3-3.1	50uF 250V	12uF 450V	5.5	10.0	150	250	2"
SV 05-MA-50											
SV 10-M-50	1.0	0.75	10.6-9.2	5.3-4.9	80uF 250V	20uF 450V	8.0	14.0	200	350	2"
SV 10-MA-50											
SV 20-M-50	2.0	1.5	-	10.0-9.2	-	40UF 450V	14.0	21.0	200	410	2"
SV 20-MA-50											
SV 20E-M-50	2.0	1.5	-	10.0-9.2	-	40UF 450V	8.5	16.0	400	640	2"
SV 20E-MA-50											
SV 20E-M-80	2.0	1.5	-	10.0-9.2	-	40UF 450V	8.5	16.0	400	640	3"
SV 20E-MA-80											

A = Auto Float Switch

Three Phase

Model	Power		Current(A)			Head		Flow		Discharge inch
	Single Phase	HP	Kw	220-230V	380-440V	460-480V	Rated (M)	Max (M)	Rated (L/min)	
SV 05-T-50	0.5	0.37	2.3-2.2	1.3-1.2	1.3-1.2	5.5	10.0	150	250	2"
SV 10-T-50	1.0	0.5	3.4-3.3	2.1-2.0	1.9-1.7	8.0	14.0	200	350	2"
SV 20-T-50	2.0	1.5	6.3-6.0	3.6-3.4	3.2-3.0	14.0	21.0	200	410	2"
SV 20E-T-50	2.0	1.5	6.3-6.0	3.6-3.4	3.2-3.0	8.5	16.0	400	640	2"
SV 20E-T-80	2.0	1.5	6.3-6.0	3.6-3.4	3.2-3.0	8.5	16.0	400	640	3"
SV 30E-T-50	3.0	2.2	8.8-8.5	5.0-4.8	4.8-4.7	13.0	20.0	400	800	2"
SV 30E-T-80	3.0	2.2	8.8-8.5	5.0-4.8	4.8-4.7	13.0	20.0	400	800	3"
SV 50E-T-80	5.0	3.7	13.6-13.0	8.0-7.8	7.5-7.3	18.0	26.5	500	950	3"
SV 50E-T-100	5.0	3.7	13.6-13.0	8.0-7.8	7.5-7.3	18.0	26.5	500	950	4"
SV 75E-T-80	7.5	5.5	20.0-18.5	12.0-11.0	10.5-9.5	22.0	35.0	640	1200	3"
SV 75E-T-100	7.5	5.5	20.0-18.5	12.0-11.0	10.5-9.5	22.0	35.0	640	1200	4"

Dimensions

Model	Discharge[mm]								Solid Passage [mm]	Cable-10M H07 RN-F	N.W. [kg]
	H	H1	H2	H3	A	B	C	D			
SV 05-M-50	406	352	110	124	240	201	–	153	35	3G1.0mm ²	17.0
SV 05-MA-50	406	352	110	124	240	201	–	153	35	3G1.0mm ²	17.5
SV 10-M-50	406	372	110	124	240	201	–	153	35	3G1.0mm ²	18.5
SV 10-MA-50	406	372	110	124	240	201	–	153	35	3G1.0mm ²	19.0
SV 20-M-50	520	454	100	112	279	240	–	186	35	3G1.5mm ²	30.0
SV 20-MA-50	520	454	100	112	279	240	–	186	35	3G1.5mm ²	30.5
SV 20E-M-50	526	496	141	205	395	340	252	186	50	3G1.5mm ²	37.0
SV 20E-MA-50	526	496	141	205	395	340	252	186	50	3G1.5mm ²	37.5
SV 20E-M-80	526	496	141	205	395	340	252	186	50	3G1.5mm ²	37.0
SV 20E-MA-80	526	496	141	205	395	340	252	186	50	3G1.5mm ²	37.5
SV 05-T-50	406	352	110	124	240	201	–	153	35	4G1.0mm ²	16.0
SV 10-T-50	426	372	110	124	240	201	–	153	35	4G1.0mm ²	17.5
SV 20-T-50	480	414	100	112	279	240	–	186	35	4G1.5mm ²	27.0
SV 20E-T-50	522	456	141	205	395	340	255	186	50	4G1.5mm ²	34.0
SV 20E-T-80	522	456	141	205	395	340	255	186	50	4G1.5mm ²	34.0
SV 30E-T-50	522	456	141	205	395	340	255	186	50	4G1.5mm ²	36.5
SV 30E-T-80	522	456	141	205	395	340	255	186	50	4G1.5mm ²	36.5
SV 50E-T-80	542	476	141	240	428	335	255	186	50	4G2.5mm ²	40.5
SV 50E-T-100	542	476	141	240	428	335	255	186	50	4G2.5mm ²	40.5
SV 75E-T-80	680	579	158	253	472	380	294	227	50	4G2.5mm ²	61.0
SV 75E-T-100	680	579	158	253	472	380	294	227	50	4G2.5mm ²	61.0

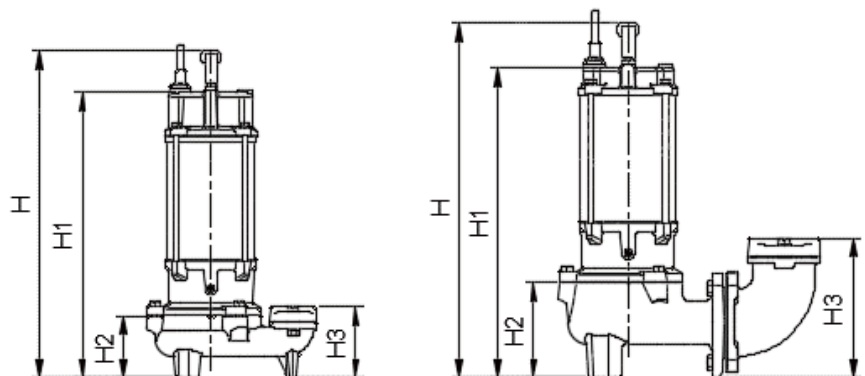
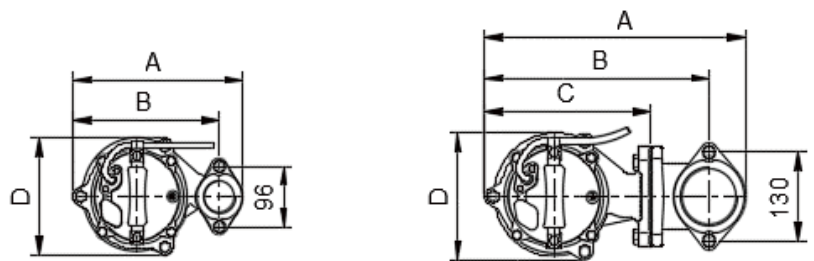



Model Code

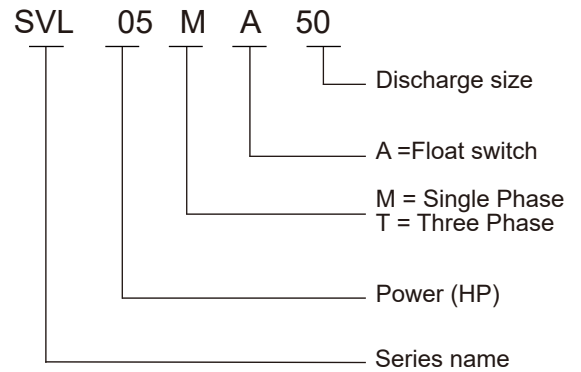

Applications

- Basement water removal
- Waste water drainage
- Water transfer
- Sump/effluent handling
- Dewatering
- Fish pond & fountain circulation
- Factory waste water handling

Motor Data

- Motor Type : 2 POLE , dry type
- Frequency : 60Hz
- Nominal Speed : 3450 rpm
- Insulation Class : F class (155°C)
- Enclosure Protection Class : IP 68
- Protection Device :
Thermal Protector (Single phase)
Overload Protector(Three phase)

Pump Data

- Impeller : Open Impeller
- Shaft Seal / Mechanical :
Double Seals
- Bearing :
Double-shielded Ball Bearing

Operation Conditions

- Fluid Temperature: 0 to 40°C (104°F)

Material

NO.	Component	Material
1	Cable	H07RN-F
2	Handle	Nylon6+30GF
3	Motor cover	FC200
4	Bearing cap	FC200
5	Motor frame	AISI 304
6	Bearing Bracket	FC200
7	M.Seal Bracket	FC200
8	Motor Shaft	AISI410
9	Mechanical seal	CA / CE, SIC/SIC
10	Oil Seal	NBR70
11	Impeller	FC250
12	Pump casing	FC200
13	Flange	FC200

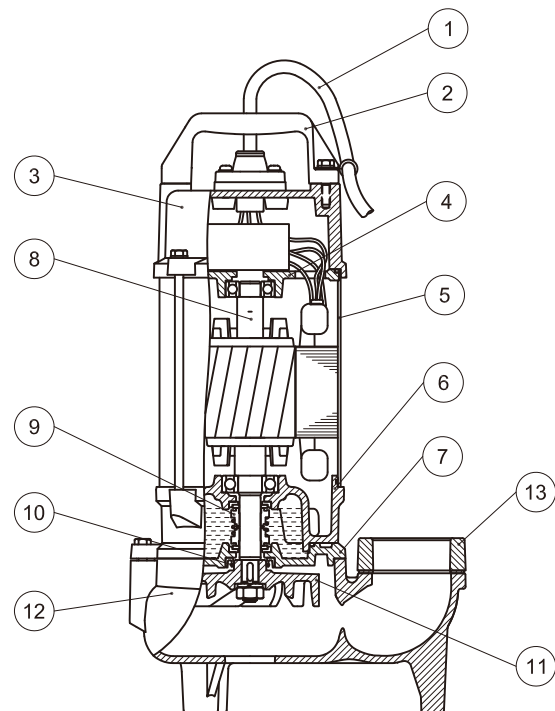

Performance Curves

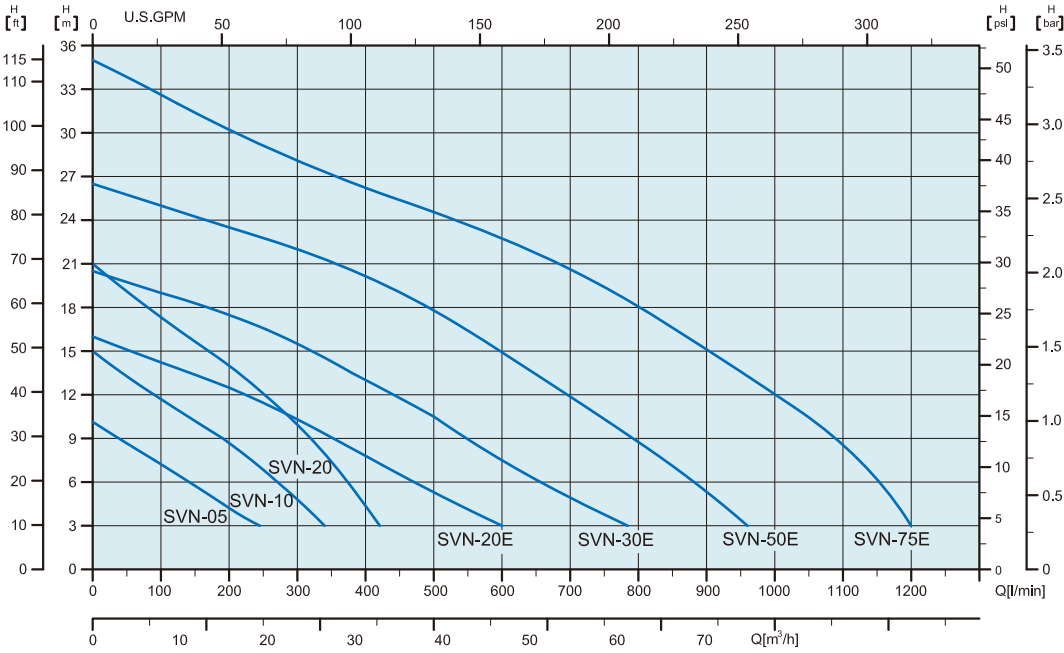

Technical Data

Single Phase

Model	Power		Current(A)		Capacitoret		Head		Flow		Discharge inch
	HP	Kw	110-127V	220-230V	110-127V UF/V	220-230V UF/V	Rated (M)	Max (M)	Rated (L/min)	Max (L/min)	
SVL 05-M-50	0.5	0.37	6.6-5.7	3.3-3.1	50uF 250V	12uF 450V	4.0	7.0	200	300	2"
SVL 05-MA-50											
SVL 10-M-50	1.0	0.75	10.6-9.2	5.3-4.9	80uF 250V	20uF 450V	6.0	11.0	250	400	2"
SVL 10-MA-50											
SVL 05-M-80	0.5	0.37	6.6-5.7	3.3-3.1	50uF 250V	12uF 450V	4.0	7.0	200	300	3"
SVL 05-MA-80											
SVL 10-M-80	1.0	0.75	10.6-9.2	5.3-4.9	80uF 250V	20uF 450V	6.0	11.0	250	400	3"
SVL 10-MA-80											

A = Auto Float Switch

Three Phase

Model	Power		Current(A)			Head		Flow		Discharge inch
	HP	Kw	220-230V	380-440V	460-480V	Rated (M)	Max (M)	Rated (L/min)	Max (L/min)	
SVL 05-T-50	0.5	0.37	2.3-2.2	1.3-1.2	1.3-1.2	4.0	7.0	200	300	2"
SVL 10-T-50	1.0	0.5	3.4-3.3	2.1-2.0	1.9-1.7	6.0	11.0	250	400	2"
SVL 05-T-80	0.5	0.37	2.3-2.2	1.3-1.2	1.3-1.2	4.0	7.0	200	300	3"
SVL 10-T-80	1.0	0.5	3.4-3.3	2.1-2.0	1.9-1.7	6.0	11.0	250	400	3"

Dimensions

Model	Discharge[mm]								Solid Passage [mm]	Cable-10M	N.W.
	H	H1	H2	H3	A	B	C	D		H07 RN-F	[kg]
SVL 05-M-50	437	383	141	143	247	208	–	166	50	3G1.0mm ²	19.0
SVL 05-MA-50	437	383	141	143	247	208	–	166	50	3G1.0mm ²	19.5
SVL 10-M-50	457	403	141	143	247	208	–	166	50	3G1.0mm ²	20.7
SVL 10-MA-50	457	403	141	143	247	208	–	166	50	3G1.0mm ²	21.2
SVL 05-M-80	437	383	141	143	283	227	–	166	50	3G1.5mm ²	19.0
SVL 05-MA-80	437	383	141	143	283	227	–	166	50	3G1.5mm ²	19.5
SVL 10-M-80	457	403	141	143	283	227	–	166	50	3G1.5mm ²	20.7
SVL 10-MA-80	457	403	141	143	283	227	–	166	50	3G1.5mm ²	21.2
SVL 05-T-50	437	383	141	143	247	208	–	166	50	3G1.5mm ²	18.0
SVL 10-T-50	457	403	141	143	247	208	–	166	50	3G1.5mm ²	19.5
SVL 05-T-80	437	383	141	143	283	227	–	166	50	4G1.0mm ²	18.0
SVL 10-T-80	457	403	141	143	283	227	–	166	50	4G1.0mm ²	19.5

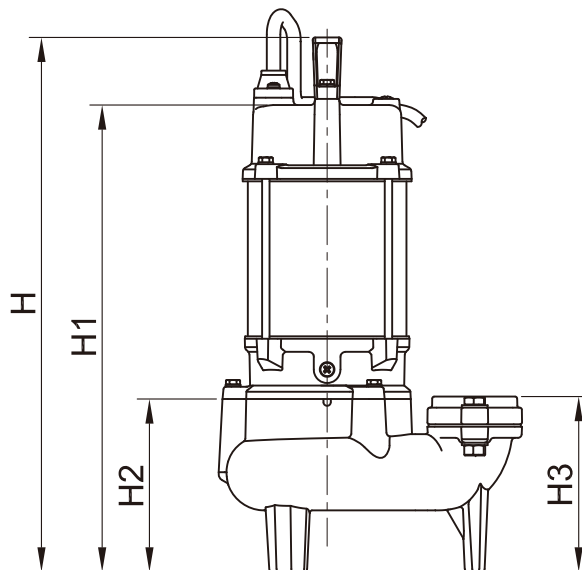
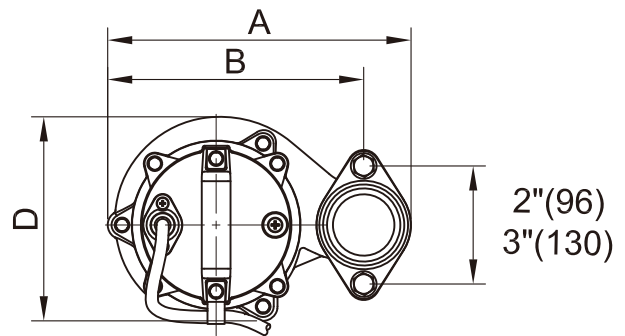



Model Code

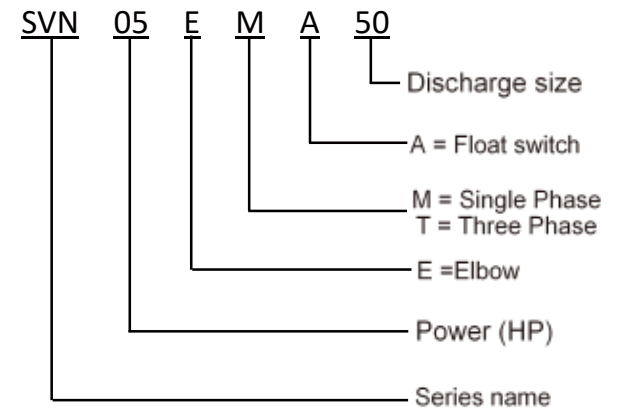

Applications

- Basement water removal
- Waste water drainage
- Water transfer
- Sump/effluent handling
- Dewatering
- Fish pond & fountain circulation
- Factory waste water handling

Motor Data

- Motor Type : 2 POLE , dry type
- Frequency : 60Hz
- Nominal Speed : 3450 rpm
- Insulation Class : F class (155°C)
- Enclosure Protection Class : IP 68
- Protection Device :
Thermal Protector (Single phase)
Overload Protector(Three phase)

Pump Data

- Impeller : Open Impeller
- Shaft Seal / Mechanical :
Double Seals
- Bearing :
Double-shielded Ball Bearing

Operation Conditions

- Fluid Temperature: 0 to 40°C (104°F)

Material

No.	Component	Material
1	Cable	H07RN-F
2	Handle	Nylon6+30GF AISI304+NBR
3	Motor cover	CF8M
4	Bearing cap	FC200
5	Motor frame	AISI 304
6	Bearing Bracket	CF8M
7	M.Seal Bracket	CF8M
8	Motor Shaft	AISI410
9	Mechanical seal	CA / CE, SIC/SIC
10	Oil Seal	VITON70
11	Impeller	CF8M
12	Pump casing	CF8M
13	Flange	CF8M

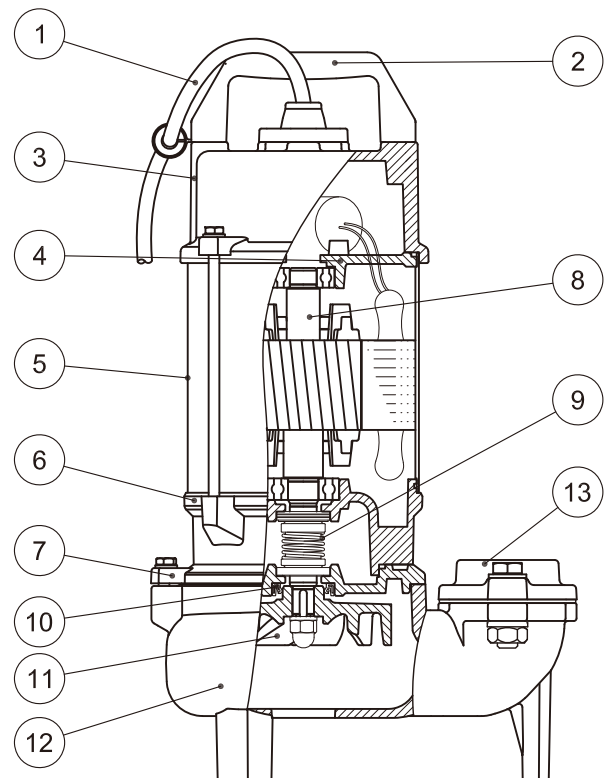

Performance Curves

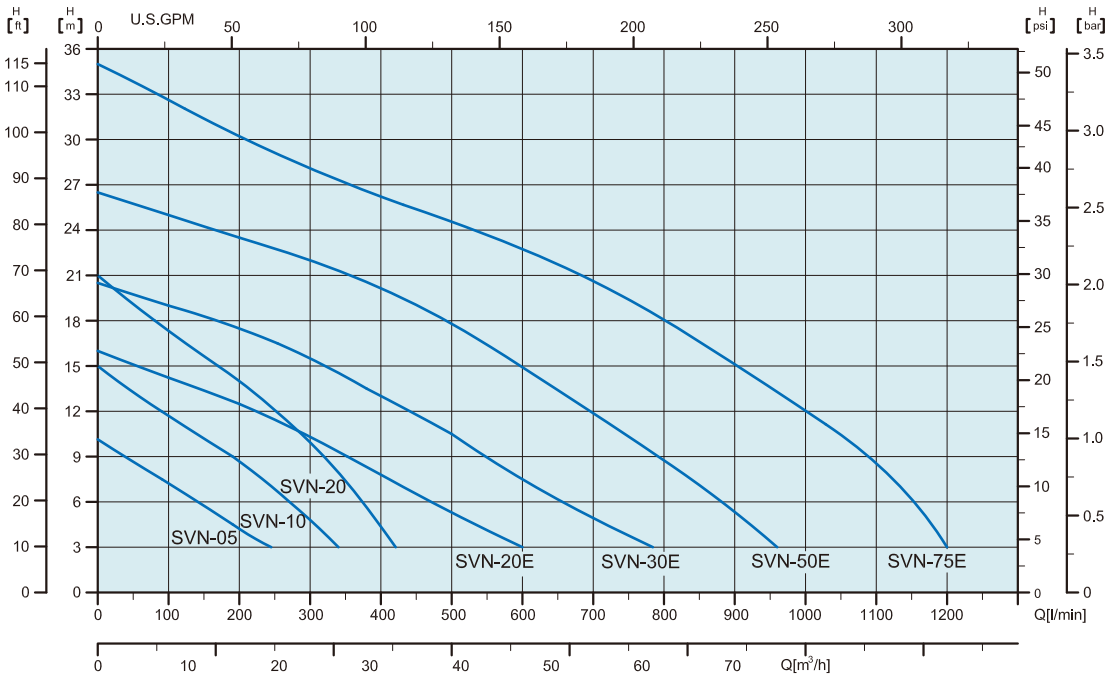

Technical Data

Single Phase

Model	Power		Current(A)		Capacitoret		Head		Flow		Discharge inch
	HP	Kw	110-127V	220-230V	110-127V UF / V	220-230V UF / V	Rated (M)	Max (M)	Rated (L/min)	Max (L/min)	
SVN 05-M-50	0.5	0.37	6.6-5.7	3.3-3.1	50uF 250V	12uF 450V	5.5	10.0	150	250	2"
SVN 05-MA-50											
SVN 10-M-50	1.0	0.75	10.6-9.2	5.3-4.9	80uF 250V	20uF 450V	8.0	12.0	200	350	2"
SVN 10-MA-50											
SVN 20-M-50	2.0	1.5	-	10.0-9.2	-	40UF 450V	14.0	21.0	200	410	2"
SVN 20-MA-50											
SVN 20E-M-50	2.0	1.5	-	10.0-9.2	-	40UF 450V	8.5	16.0	400	640	2"
SVN 20E-MA-50											
SVN 20E-M-80	2.0	1.5	-	10.0-9.2	-	40UF 450V	8.5	16.0	400	640	3"
SVN 20E-MA-80											

Three Phase

Model	Power		Current(A)			Head		Flow		Discharge inch
	HP	Kw	220-230V	380-440V	460-480V	Rated (M)	Max (M)	Rated (L/min)	Max (L/min)	
SVN 05-T-50	0.5	0.37	2.3-2.2	1.3-1.2	1.3-1.2	5.5	10.0	150	250	2"
SVN 10-T-50	1.0	0.5	3.4-3.3	2.1-2.0	1.9-1.7	8.0	12.0	200	350	2"
SVN 20-T-50	2.0	1.5	6.3-6.0	3.6-3.4	3.2-3.0	14.0	21.0	200	410	2"
SVN 20E-T-50	2.0	1.5	6.3-6.0	3.6-3.4	3.2-3.0	8.5	16.0	400	640	2"
SVN 20E-T-80	2.0	1.5	6.3-6.0	3.6-3.4	3.2-3.0	8.5	16.0	400	640	3"
SVN 30E-T-50	3.0	2.2	8.8-8.5	5.0-4.8	4.8-4.7	12.0	20.0	400	800	2"
SVN 30E-T-80	3.0	2.2	8.8-8.5	5.0-4.8	4.8-4.7	12.0	20.0	400	800	3"
SVN 50E-T-80	5.0	3.7	13.6-13.0	8.0-7.8	7.5-7.3	18.0	26.5	500	950	3"
SVN 50E-T-100	5.0	3.7	13.6-13.0	8.0-7.8	7.5-7.3	18.0	26.5	500	950	4"
SVN 75E-T-80	7.5	5.5	20.0-18.5	12.0-11.0	10.5-9.5	22.0	35.0	640	1200	3"
SVN 75E-T-100	7.5	5.5	20.0-18.5	12.0-11.0	10.5-9.5	22.0	35.0	640	1200	4"

Dimensions

Model	Discharge[mm]								Solid Passage [mm]	Cable-10M H07 RN-F	N.W. [kg]
	H	H1	H2	H3	A	B	C	D			
SVN 05-M-50	406	352	110	124	240	201	–	153	35	3G1.0mm ²	15.5
SVN 05-MA-50	406	352	110	124	240	201	–	153	35	3G1.0mm ²	16.0
SVN 10-M-50	406	372	110	124	240	201	–	153	35	3G1.0mm ²	17.0
SVN 10-MA-50	406	372	110	124	240	201	–	153	35	3G1.0mm ²	17.5
SVN 20-M-50	520	454	100	112	279	240	–	186	35	3G1.5mm ²	28.0
SVN 20-MA-50	520	454	100	112	279	240	–	186	35	3G1.5mm ²	28.5
SVN 20E-M-50	526	496	141	205	395	340	252	186	50	3G1.5mm ²	34.0
SVN 20E-MA-50	526	496	141	205	395	340	252	186	50	3G1.5mm ²	34.5
SVN 20E-M-80	526	496	141	205	395	340	252	186	50	3G1.5mm ²	34.0
SVN 20E-MA-80	526	496	141	205	395	340	252	186	50	3G1.5mm ²	34.5
SVN 05-T-50	406	352	110	124	240	201	–	153	35	4G1.0mm ²	13.0
SVN 10-T-50	426	372	110	124	240	201	–	153	35	4G1.0mm ²	14.5
SVN 20-T-50	480	414	100	112	279	240	–	186	35	4G1.5mm ²	25.5
SVN 20E-T-50	522	456	141	205	395	340	255	186	50	4G1.5mm ²	32.0
SVN 20E-T-80	522	456	141	205	395	340	255	186	50	4G1.5mm ²	32.0
SVN 30E-T-50	522	456	141	205	395	340	255	186	50	4G1.5mm ²	34.0
SVN 30E-T-80	522	456	141	205	395	340	255	186	50	4G1.5mm ²	34.0
SVN 50E-T-80	542	476	141	240	428	335	255	186	50	4G2.5mm ²	41.0
SVN 50E-T-100	542	476	141	240	428	335	255	186	50	4G2.5mm ²	41.0
SVN 75E-T-80	680	579	158	253	472	380	294	227	50	4G2.5mm ²	57.0
SVN 75E-T-100	680	579	158	253	472	380	294	227	50	4G2.5mm ²	57.0

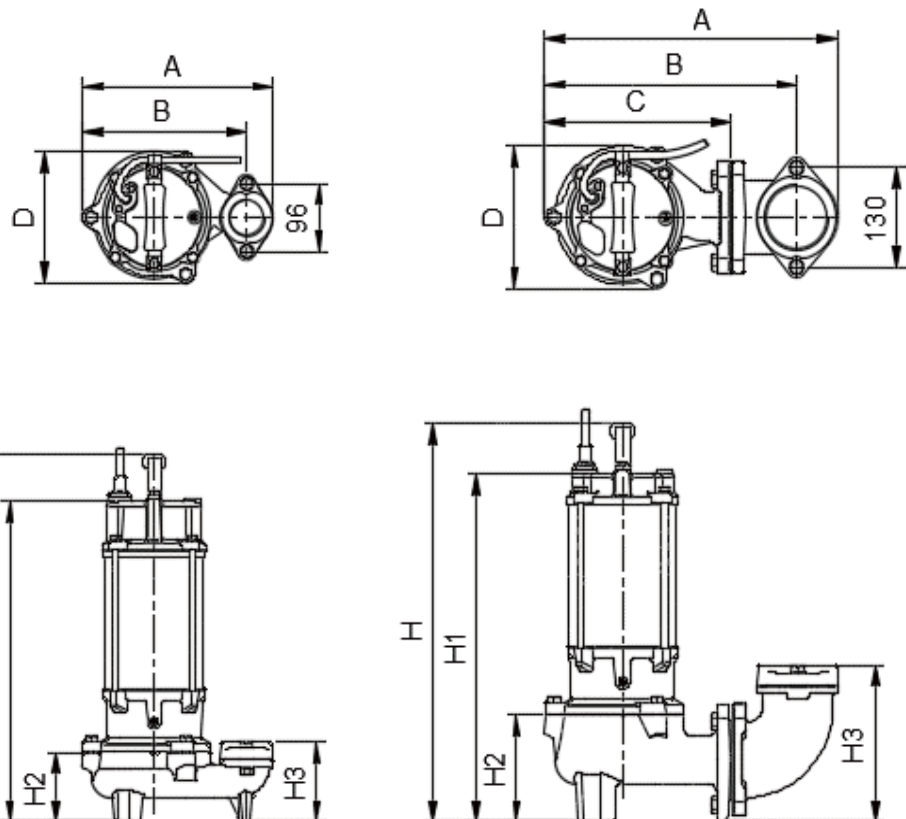

TS-50

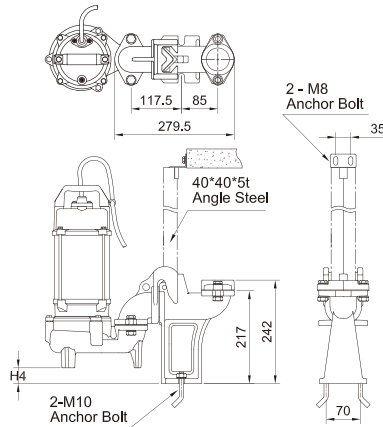

Model	TS-50 Guide Rail	
	DN (mm)	Dimensions H4(mm)
SD-05-50	50	31
SD-10-50	50	31
SV-05-50	50	37
SV-10-50	50	37
SV-20-50	50	45
SVL-05-50	50	15
SVL-10-50	50	15
HM-05-50	50	48

TSL-50/80

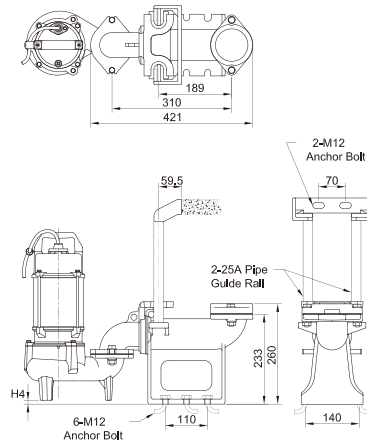

Model	TSL-50/80 Guide Rail	
	DN (mm)	Dimensions H4(mm)
SVL-05-80	80	10
SVL-10-80	80	10
HM-10-50	50	43
HM-10-80	80	43

TM-50/80

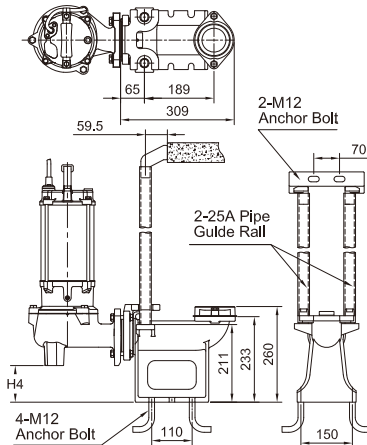

Model	TM-50/80 Guide Rail	
	DN (mm)	Dimensions H4(mm)
SD-20E-50	50	77.5
SD-20E-80	80	77.5
SD-30E-50	50	77.5
SD-30E-80	80	77.5
SV-20E-50	50	99.5
SV-20E-80	80	99.5
SV-30E-50	50	99.5
SV-30E-80	80	99.5

TL-80/100

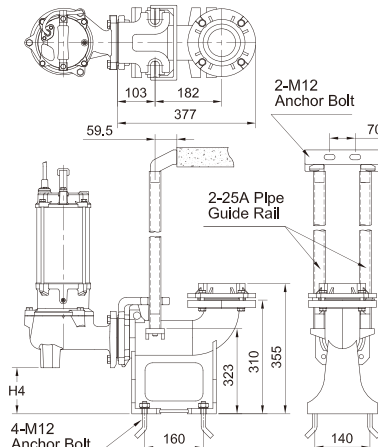

Model	TL-80/100 Guide Rail	
	DN (mm)	Dimensions H4(mm)
SD-50E-80	80	104.5
SD-50E-100	100	104.5
SD-75E-80	80	104.5
SD-75E-100	100	104.5
SV-50E-80	80	126.5
SV-50E-100	100	126.5
SV-75E-80	80	126.5
SV-75E-100	100	126.5

STS-50

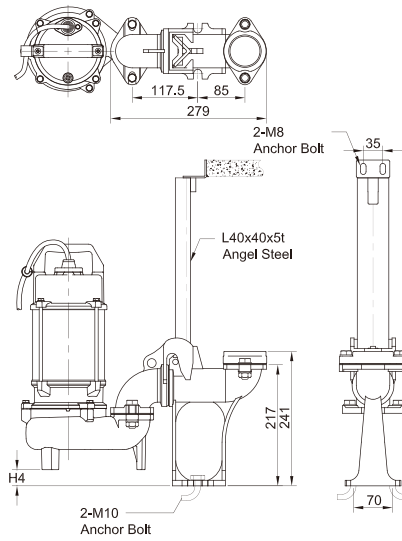

Model	STS-50 Guide Rail	
	DN (mm)	Dimensions H4(mm)
SVN-05-50	50	29
SVN-10-50	50	29
SVN-20-50	50	40

STM-50/80

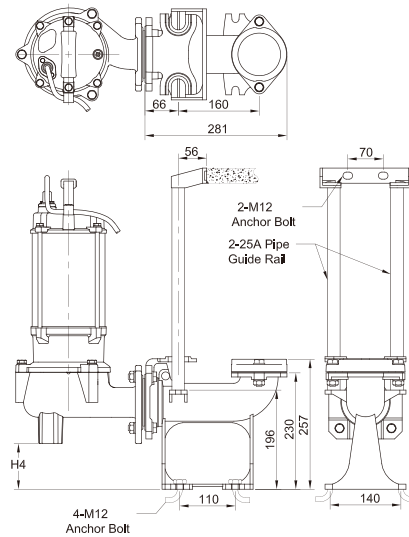

Model	STM-50/80 Guide Rail	
	DN (mm)	Dimensions H4(mm)
SVN-20E-50	50	90
SVN-20E-80	80	90
SVN-30E-50	50	90
SVN-30E-80	80	90

STL-80/100

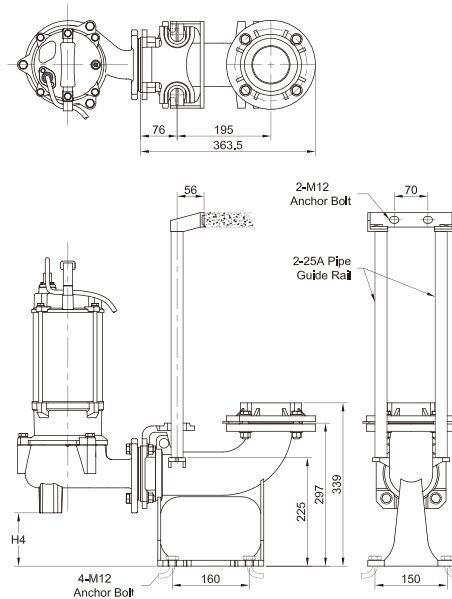

Model	STL-80/100 Guide Rail	
	DN (mm)	Dimensions H4(mm)
SVN-50E-80	80	110.5
SVN-50E-100	100	110.5
SVN-75E-80	80	104
SVN-75E-100	100	104



Model Code

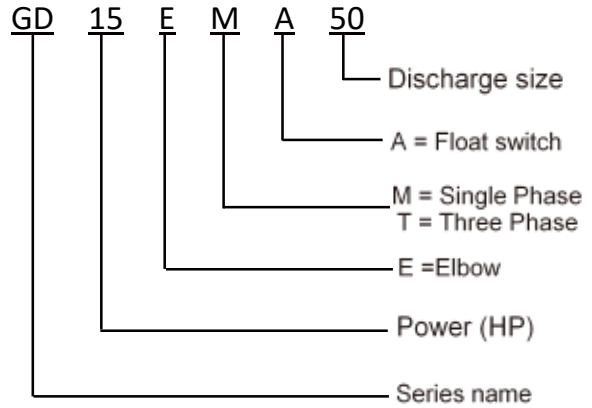

Applications

- General household use, Drainage systems for Buildings, Apartments, Resorts and Wastewater systems.
- Materials such as leather, textile fibres, food and other tougher objects can be pumped.
- Wastewater systems for Domestic, Commercial, Industrial, Municipal, Schools, Hospitals and many other uses.
- Sewage and Drainage systems.

Advantages

- Robust construction.
- Superior Heat Dissipation.
- Macerating Impellor for cutting up materials.
- Double mechanical seals Upper : CA/CE Lower : SIC/SIC

Material

NO.	Component	Material
1	Cable	H07RN-F
2	Handle	AISI304+NBR
3	Motor cover	FC200
4	Bearing cap	FC200
5	Motor frame	FC200
6	Bearing Bracket	FC200
7	M.Seal Bracket	FC200
8	Motor Shaft	AISI 410
9	Mechanical seal	CA / CE, SIC/SIC
10	Oil Seal	NBR70
11	Impeller	FC250
12	Pump casing	FC200
13	Radidl cutter	AISI 440C
14	Cutter ring	AISI 440C
15	Flange	FC200

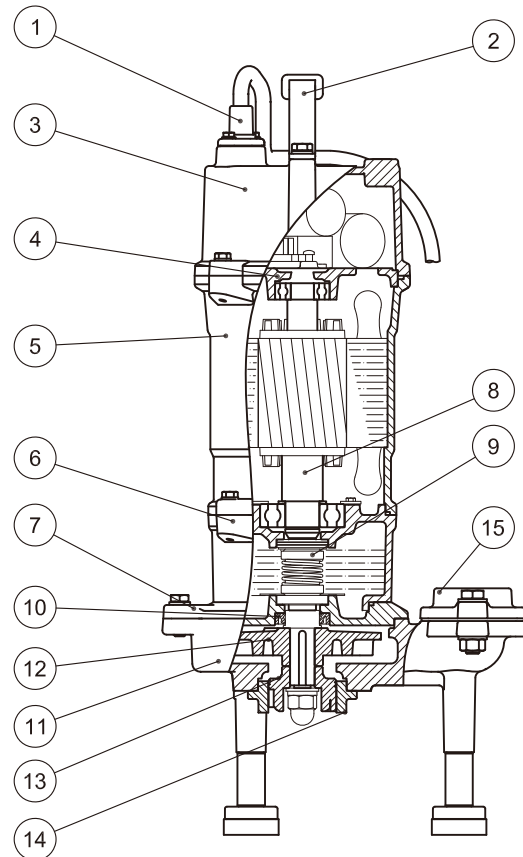

Submersible Grinder Pumps

60Hz

Performance Curves

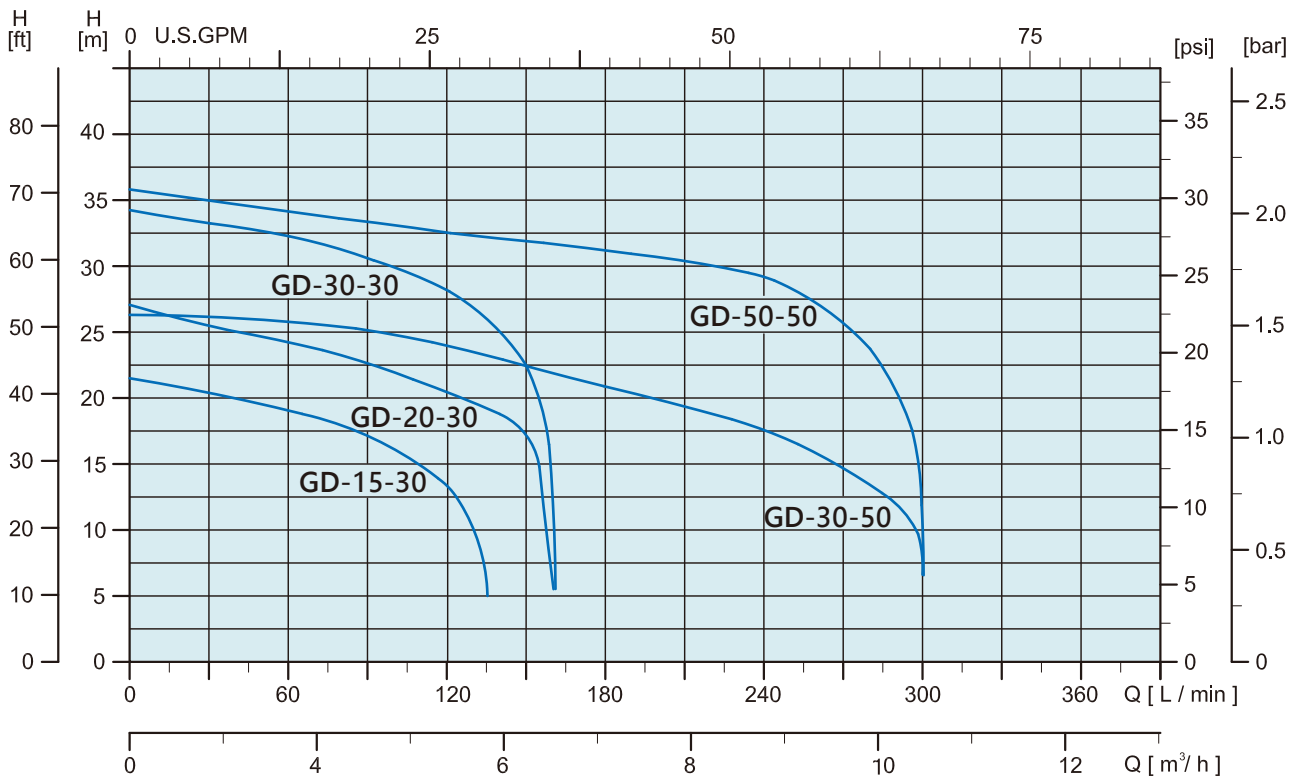

Technical Data

Single Phase

Model	Power		Current(A)	Discharge	Head		Flow		Cable	Weight
	HP	Kw			Rated (M)	Max (M)	Rated (L/min)	Max (L/min)		
GD 15-M-30	1.3	1.0	6.4-6.0	1 1/4"	16.0	21.0	60	140	10	27
GD 15-MA-30										
GD 20-M-30	2.0	1.5	10.0-9.5	1 1/4"	24.0	26.0	60	160	10	27
GD 20-MA-30										

A = Auto Float Switch

Three Phase

Model	Power		Current(A)			Discharge	Head		Flow		Cable	Weight
	HP	Kw	220-230V	380-440V	460-480V		Rated (M)	Max (M)	Rated (L/min)	Max (L/min)		
GD 15-T-30	1.3	1.0	4.2-4.0	2.4-2.0	2.0-1.9	1 1/4"	16.0	21.0	60	140	10	25
GD 20-T-30	2.0	1.5	6.0-5.7	3.5-3.0	2.8-2.6	1 1/4"	24.0	25.5	60	160	10	32
GD 30-T-30	3.0	2.2	8.6-8.2	5.0-4.3	4.1-3.9	1 1/4"	30.5	34.0	60	160	10	35
GD 30-T-50	3.0	2.2	10.2-9.7	5.9-5.0	4.8-4.6	2"	20.0	24.5	200	300	10	44
GD 50-T-50	5.0	3.7	13.8-13.2	8.0-6.9	6.6-6.3	2"	31.0	36.5	200	300	10	47

Dimensions

Model	Phase	Discharge[mm]						DN (mm)
		A	A1	D	H	H1	H2	
GD-15-30	1	267	228	96	558	491	159	32
	3				528	461	159	
GD-20-30	1	290	251	96	605	538	159	32
	3				550	483	159	
GD-30-30	3	290	251	96	550	483	159	32
GD-30E-50	3	428	268	215	569	502	237	50
GD-50E-50	3	428	268	215	589	522	237	50

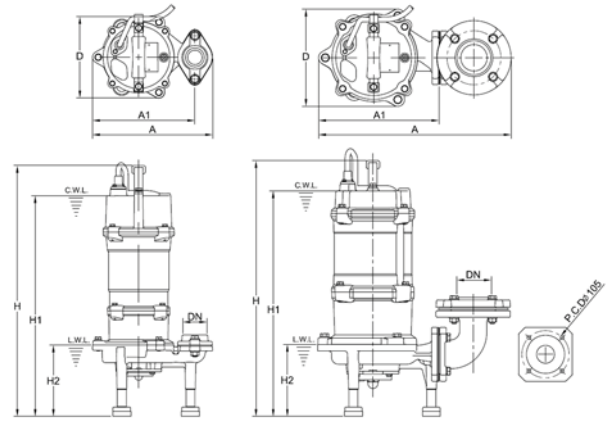

Guide Rail System

TS-32

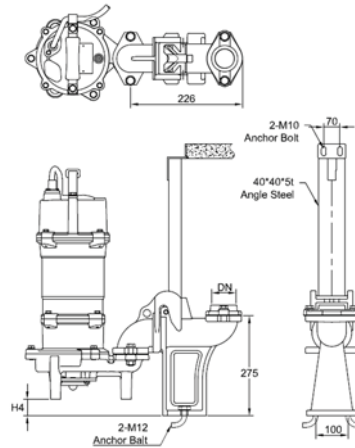

Model	TS-32 Guide Rail	
	DN (mm)	Dimensions H4 (mm)
GD-15-30	32	36
GD-20-30	32	34
GD-30-30	32	34

TG-50

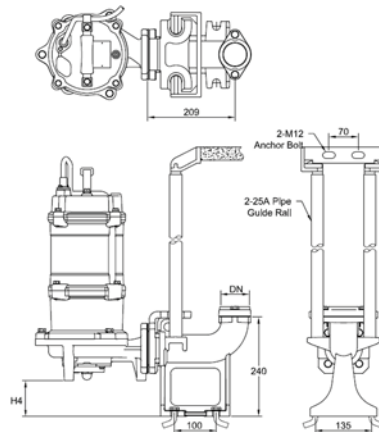

Model	TG-50 Guide Rail	
	DN (mm)	Dimensions H4 (mm)
GD-30E-50	50	88
GD-50E-50	50	88

