



# SLP 60Hz

## In-line Circulator Pumps

SLP Series is Vertical in-line Centrifugal pump in-line port position with flange designed according to DIN Standard. Standard pumps are fitted with motor according to IEC standard, with three phase premium efficiency (IE3).



**SLP**
**General Data**

Model Code	1
Applications	1
Features	1
Pumped Liquids	1
Operation Conditions	1
Motor	1
Codes for shaft seal	1
Performance range	2
Motor Data	2
Materials	3

**Technical Data**

SLP 32	4
SLP 40	6
SLP 50	8
SLP 65	10
SLP 80	12

**SLP In-line Circulator Pumps**

SLP Series is Vertical in-line Centrifugal pump, in-line port position with flange designed according to DIN Standard. Standard pumps are fitted with motor according to IEC standard, with three phase premium efficiency (IE3).



### Applications

- Hot or chilled water circulating systems
- Refrigerating systems
- Domestic and potable water system
- Industrial Water services
- Circulation and supply of potable, domestic, sanitary, brackish water, and other clean aggressive liquids.

### Pumped Liquids

The pump is suitable for thin, clean, non-aggressive and non-flammable liquids, not containing solid particles or fibres that may attack the pump mechanically or chemically.

### Operation Conditions

- Flow Rate : Up to 142.5 m<sup>3</sup>/h
- Head : Up to 43 m
- Liquid Temperature Range : -25 To +120 °C
- Maximum Ambient Temperature : +50 °C
- Maximum Operating Pressure : 16 (bar)

### Motor

The motor fitted on SLP pumps is a totally enclosed, fan-cooled motor with main dimensions to IEC and DIN standards.

Electrical tolerances to IEC 60034.

- Relative humidity : Maximum 95 %
- Enclosure class : IP55
- Insulation class : F

### Model Code

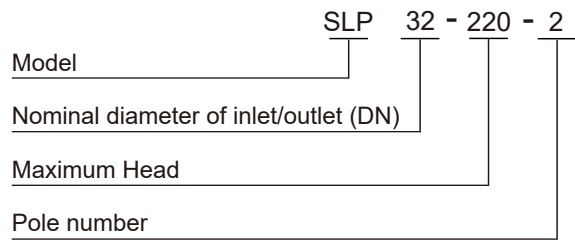

### Codes for shaft seal

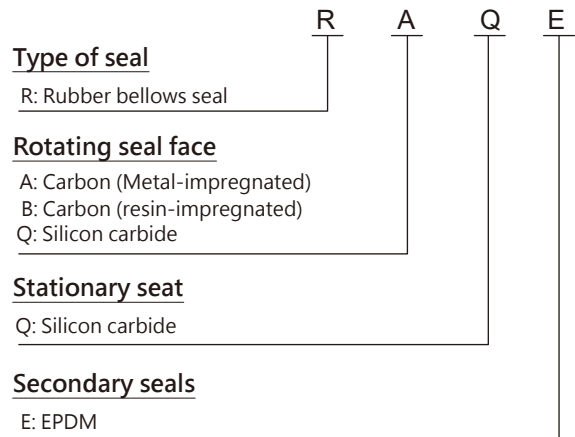

### Features

- Optimised Hydraulics For High Efficiency  
Reduced power consumption.
- High-efficiency Motors  
SLP pumps are fitted with high-efficiency motors.
- High-efficiency motors offer reduced energy consumption.  
SLP pumps are primarily fitted with motors that meet the legislative requirements of the EuP IE3 grade.
- Top-pull-out Design  
Easy dismantling in case of service.
- In-line Design  
Contrary to end-suction pumps, in-line pumps allow straight pipes and thus often reduced installation costs.
- Pump Housing And Pump Head Are Electrocoated To Improve The Corrosion Resistance

Performance range

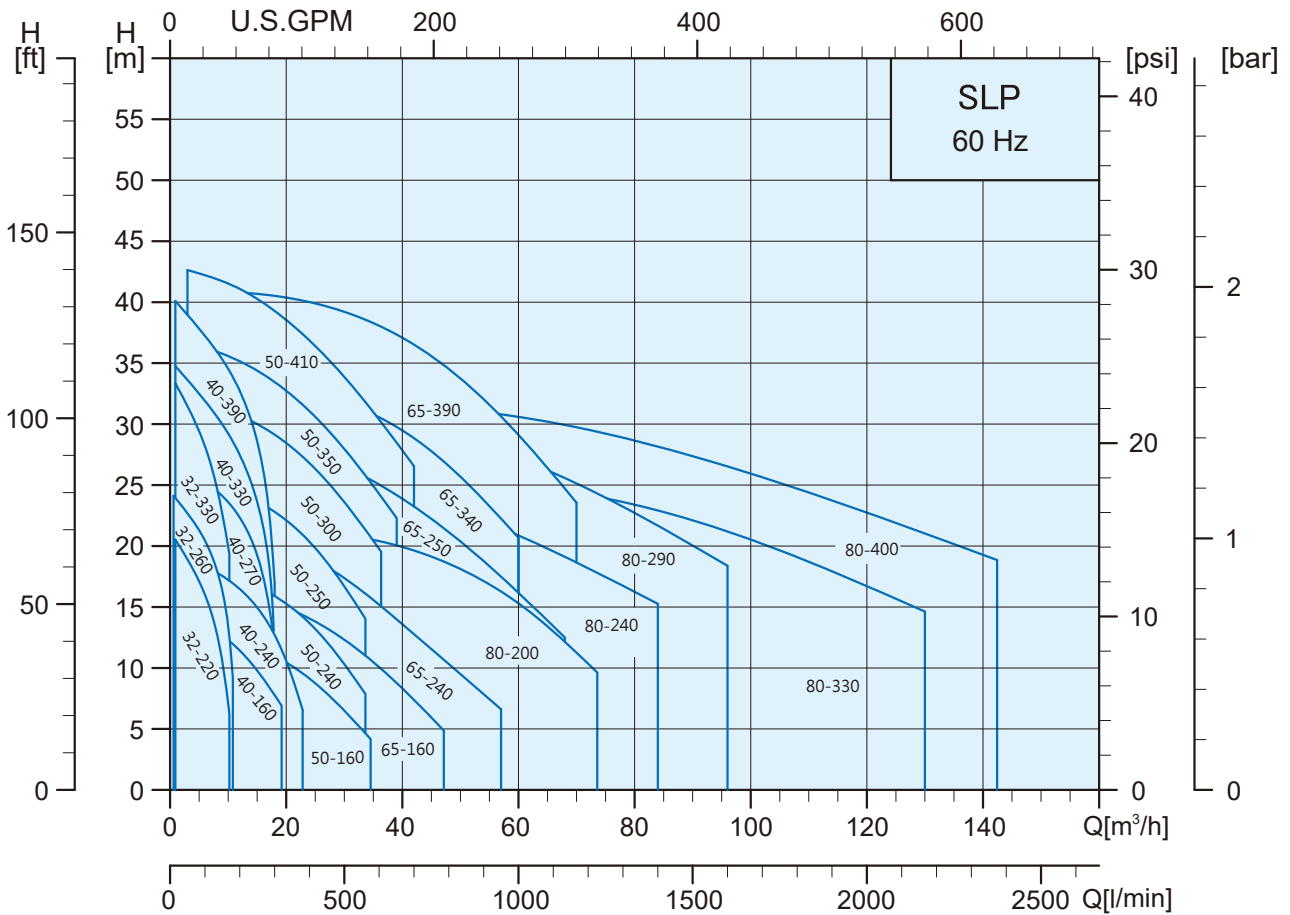

Motor Data

Series 200 Motor Type				Nominal current in [A]				IE class	
Pole	HP	kW	Flange	Frame	3Ø				
					Δ220-277V	Y380-480V	Δ380-480V		Y660-830V
2	1.0	0.75	B14 / V18	80A	3.1-3.0	1.8-1.7	—	—	IE3
	1.5	1.1		80B	4.7-4.8	2.7-2.8	—	—	IE3
	2.0	1.5		90S	5.7-5.4	3.3-3.1			IE3
	3.0	2.2		90L	8.1-7.2	4.7-4.2			IE3
	4.0	3.0		100L	11.1-9.7	6.4-5.6	6.6-5.4	3.8-3.1	IE3

Series 300 Motor Type				Nominal current in [A]				IE class	
Pole	HP	kW	Flange	Frame	3Ø				
					Δ220-277V	Y380-480V	Δ380-480V		Y660-830V
2	3.0	2.2	B5 / V1	90L	8.1-7.2	4.7-4.2			IE3
	4.0	3.0		100L	11.1-9.7	6.4-5.6	6.6-5.4	3.8-3.1	IE3
	5.5	4.0		112M	14.3-13.1	8.3-7.6	8.2-7.0	4.7-4.0	IE3
	7.5	5.5		132S	19.2-16.9	11.1-9.8	11.2-9.6	6.5-5.5	IE3
	10.0	7.5		132S	25.4-22.1	14.7-12.8	14.9-13.3	8.6-7.7	IE3
	15.0	11		160M	37.0-33.9	21.4-19.6	20.7-19.1	11.9-11	IE3
	20.0	15		160M	47.9-42.7	27.7-24.7	27.8-24.9	16-14.3	IE3



**Series 200 Materials**

Construction:

SLP Series 200 pumps are single-stage, close-coupled pumps with in-line inlet and outlet ports of identical diameter. The pumps are fitted with a fan-cooled asynchronous motor. Motor and pump shafts are connected via a rigid two-part coupling. The pumps are of the top-pull-out design, that is you can remove the power head (motor, pump head and impeller) for maintenance or service while the pump housing remains in the pipe. The pumps are equipped with Two types of unbalanced mechanical shaft seals are available as standard RBQE&RQQE

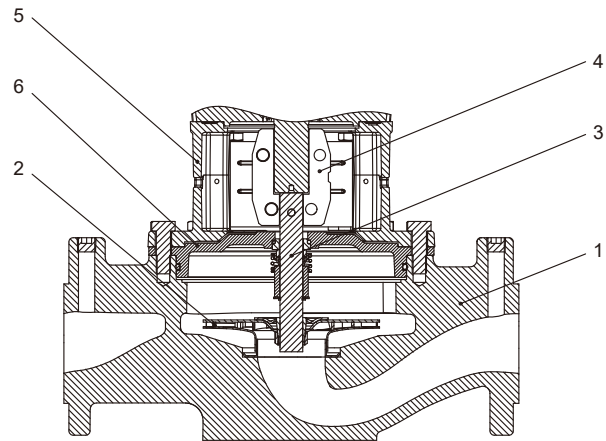

Pos.	Component	Material	EN/DIN
1	Pump housing	Cast iron FC250	0.6025
2	Impeller	Stainless steel	1.4301
3	Shaft	Stainless steel	1.4301
4	Coupling	Fe-Cu-C FC0525 (MPIF) Cast iron FCD450	0.7045
5	Pump head	Cast iron FC250	0.6025
6	Pump head cover	Cast iron FC250	0.6025
	Secondary seals	EPDM	
	Rotating seal face	– Carbon (resin-impregnated) – silicon carbide	
	Stationary seat	silicon carbide	

**Series 300 Materials**

Construction:

SLP Series 300 pumps are single-stage, close-coupled pumps with in-line inlet and outlet ports of identical diameter. The pumps are fitted with a fan-cooled asynchronous motor. Motor and pump shafts are connected via a rigid sleeve coupling. The pumps are of the top-pull-out design, that is you can remove the power head (motor, pump head and/or motor stool and impeller) or maintenance or service while the pump housing remains in the pipes. The pump housing is provided with a replaceable wear ring to ensure high pump efficiency for life. The pumps are equipped with Two types of unbalanced mechanical shaft seals are available as standard RAQE&RQQE

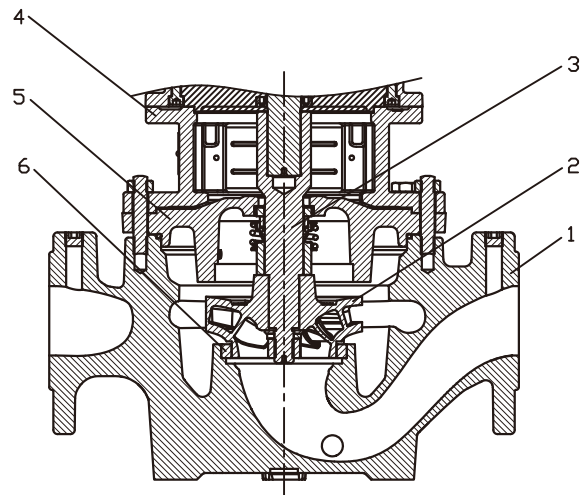

Pos.	Component	Material	EN/DIN
1	Pump housing	Cast iron FC250	0.6025
2	Impeller	Cast iron FC200	0.6020
3	Two-part stub shaft	Stainless steel /steel	1.4301 / 1.0301
4	Pump head	Cast iron FC250	0.6025
5	Pump head cover	Cast iron FC250	0.6025
6	Wear ring	Bronze CuSn10	2.1093
	Secondary seals	EPDM	
	Rotating seal face	– Carbon (resin-impregnated) – silicon carbide	
	Stationary seat	silicon carbide	

Performance Curves

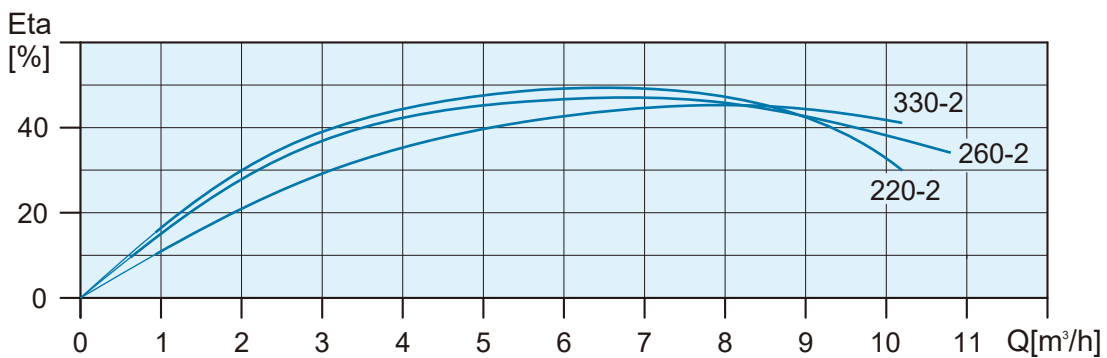
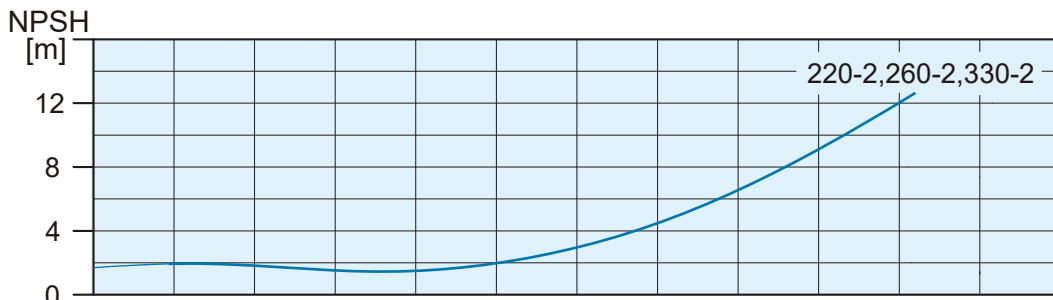
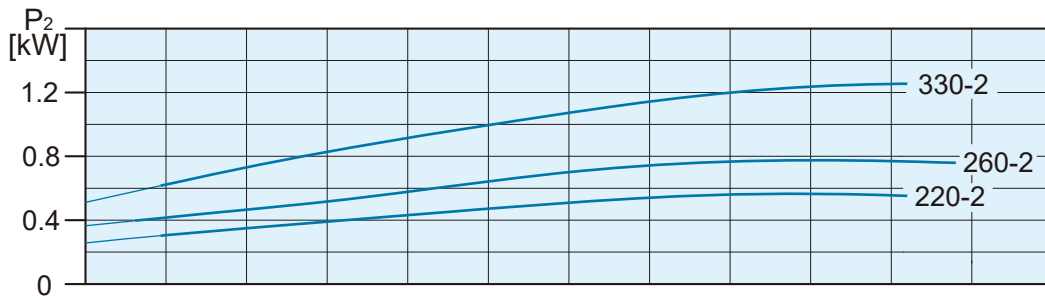
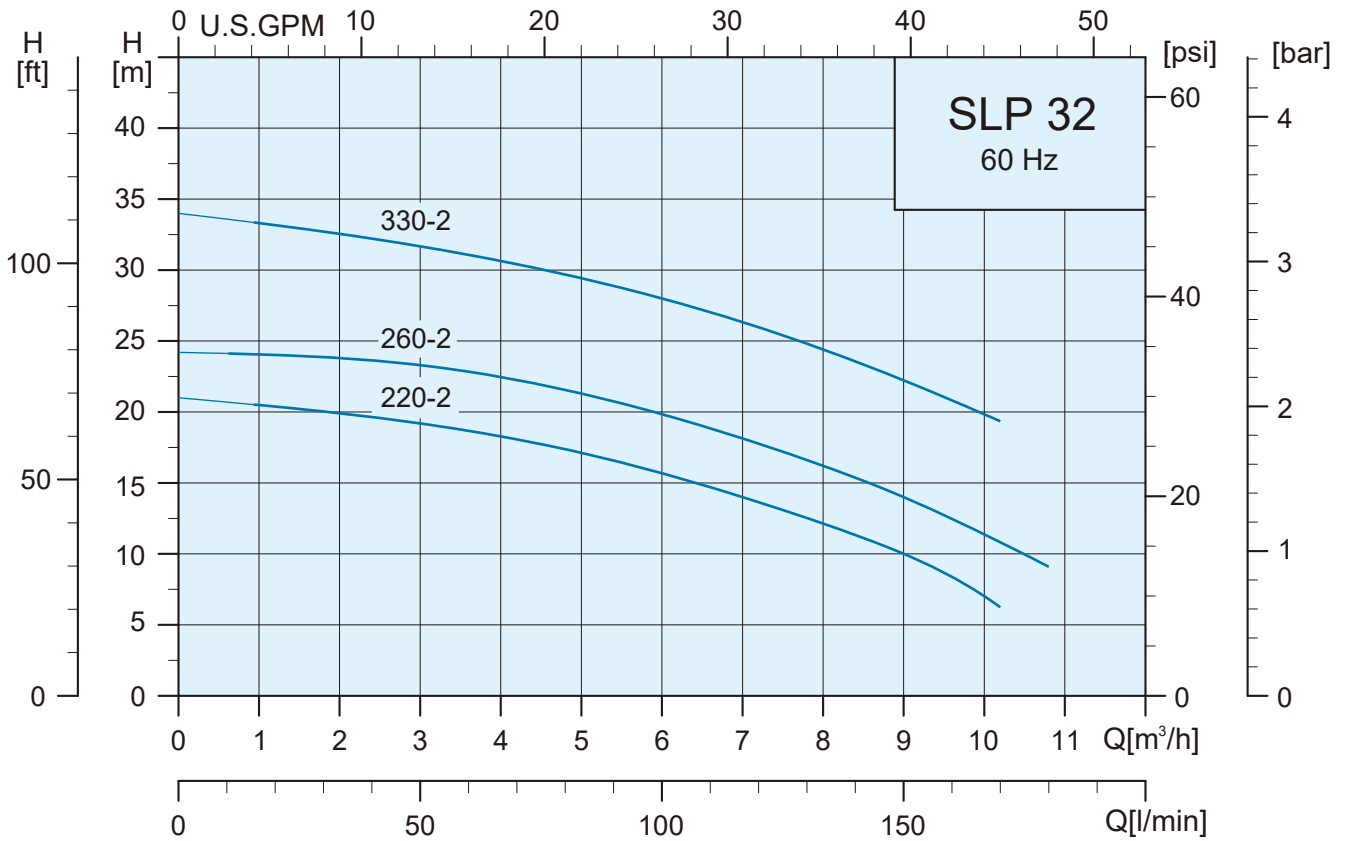

## Specifications

Model	Power		Head (Pressure)		Flow (Capacity)	Connection	T <sub>min</sub> / T <sub>max</sub>
	P <sub>2</sub>		Rated(m)	Max.(m)	Rated(m <sup>3</sup> /h)	Inlet / Outlet	°C
	kW	HP					
SLP 32-220-2	0.75	1.0	14.2	21.0	6.9	DN32	-25 / 120
SLP 32-260-2	1.1	1.5	17.2	24.0	7.5	DN32	-25 / 120
SLP 32-330-2	1.5	2.0	24.0	34.0	8.2	DN32	-25 / 120

## Dimensions and Weights

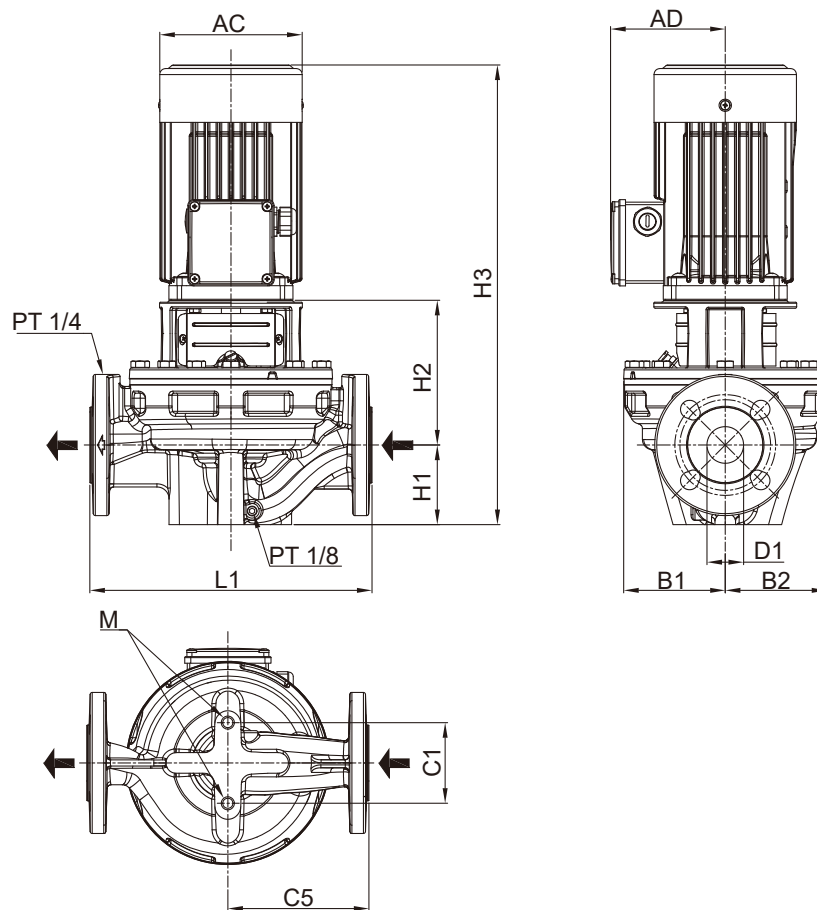

Model	Series	Flange		Dimension (mm)												Net Weight (kg)
		DIN	JIS	D1	AC	AD	B1	B2	C1	C5	L1	H1	H2	H3	M	
SLP 32-220-2	200	PN 6/10	10K	32	141	115	101	101	80	140	280	79	145	457	M12	24
SLP 32-260-2	200	PN 6/10	10K	32	141	115	101	101	80	140	280	79	145	477	M12	27
SLP 32-330-2	200	PN 6/10	10K	32	177	141	101	101	80	140	280	79	154	530	M12	34

Performance Curves

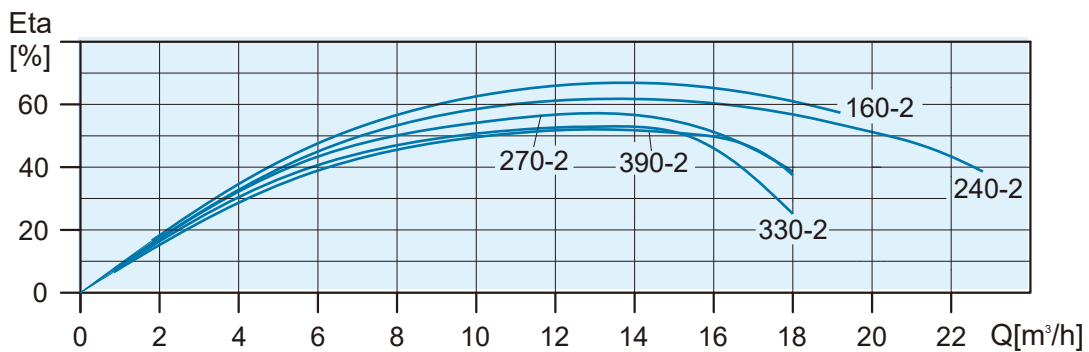
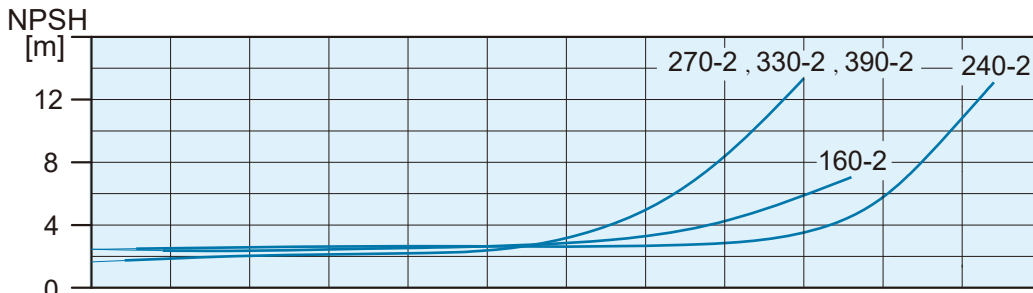
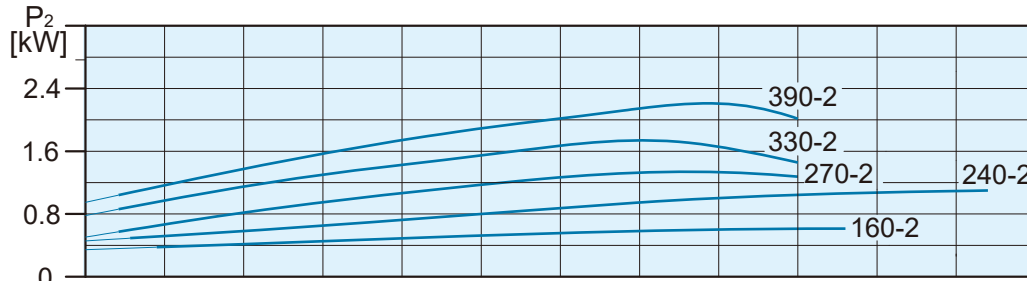
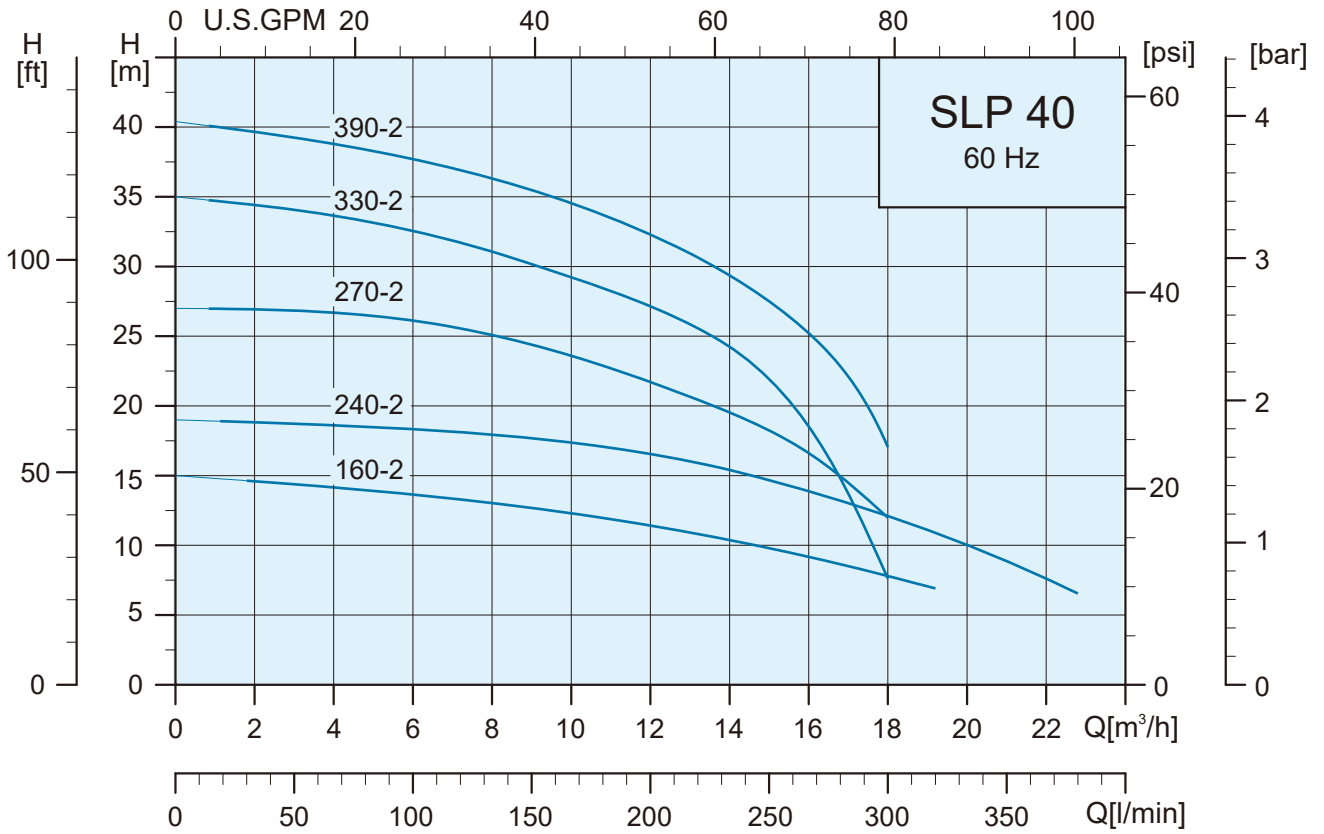



### Specifications

Model	Power		Head (Pressure)		Flow (Capacity)	Connection	T <sub>min</sub> / T <sub>max</sub>
	P <sub>2</sub>		Rated(m)	Max.(m)	Rated(m <sup>3</sup> /h)	Inlet / Outlet	°C
	kW	HP					
SLP 40-160-2	0.75	1.0	10.6	15.0	13.6	DN40	-25 / 120
SLP 40-240-2	1.1	1.5	15.8	19.0	13.4	DN40	-25 / 120
SLP 40-270-2	1.5	2.0	20.6	27.0	13.1	DN40	-25 / 120
SLP 40-330-2	2.2	3.0	23.0	35.0	14.6	DN40	-25 / 120
SLP 40-390-2	3.0	4.0	27.5	40.0	15.0	DN40	-25 / 120

### Dimensions and Weights

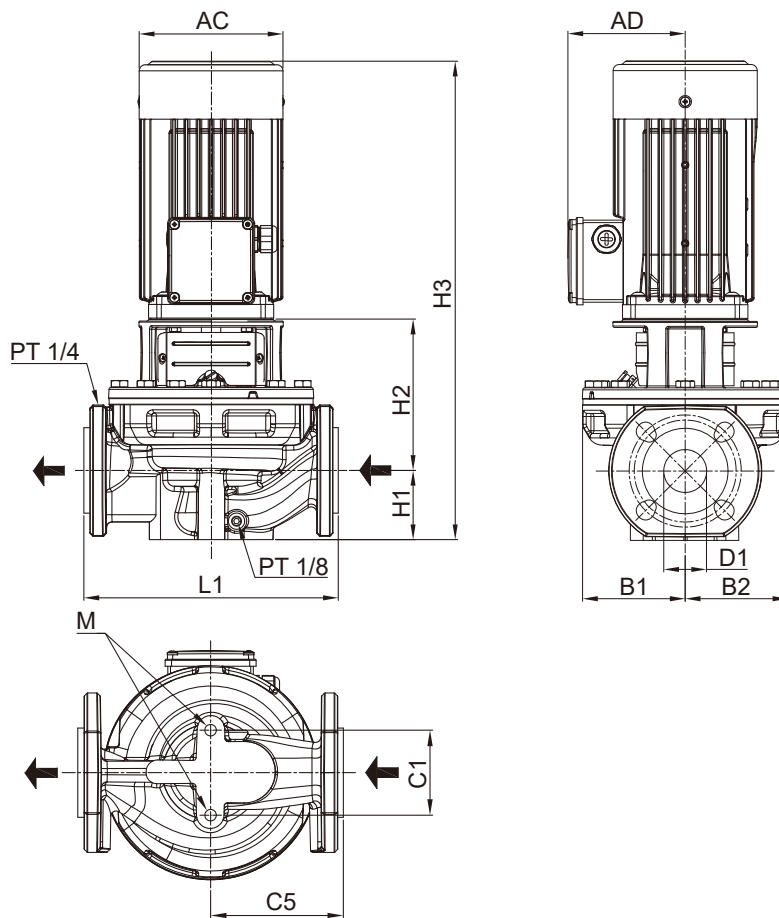

Model	Series	Flange		Dimension (mm)												Net Weight (kg)
		DIN	JIS	D1	AC	AD	B1	B2	C1	C5	L1	H1	H2	H3	M	
SLP 40-160-2	200	PN 6/10	10K	40	141	115	76	76	80	125	250	67	148	448	M12	21
SLP 40-240-2	200	PN 6/10	10K	40	141	115	101	101	80	125	250	68	150	471	M12	26
SLP 40-270-2	200	PN 16	10K	40	177	141	101	101	120	160	320	68	156	521	M12	34
SLP 40-330-2	200	PN 16	10K	40	177	141	101	101	120	160	320	68	156	521	M12	38
SLP 40-390-2	200	PN 16	10K	40	197	147	101	101	120	160	320	68	166	552	M12	45

Performance Curves

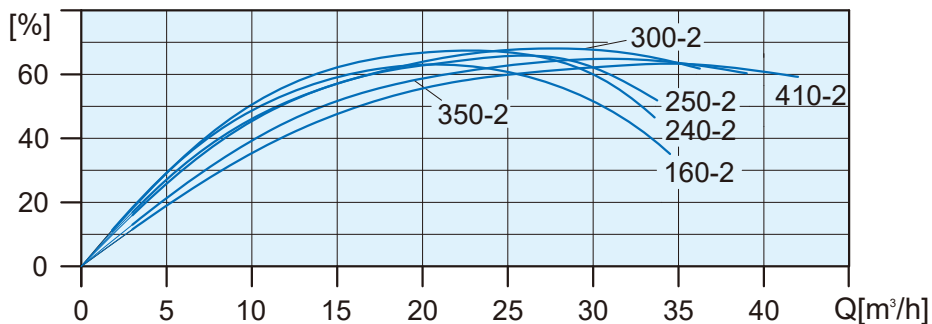
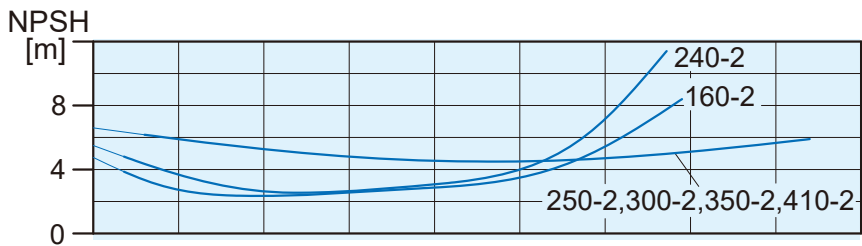
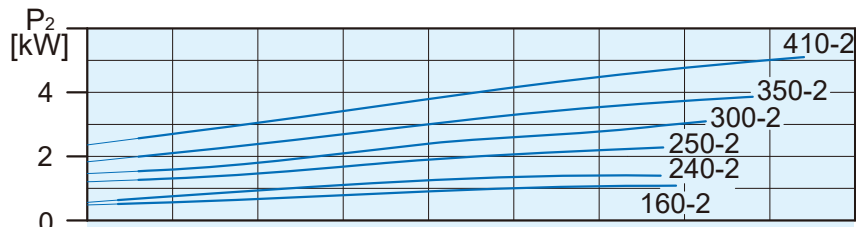
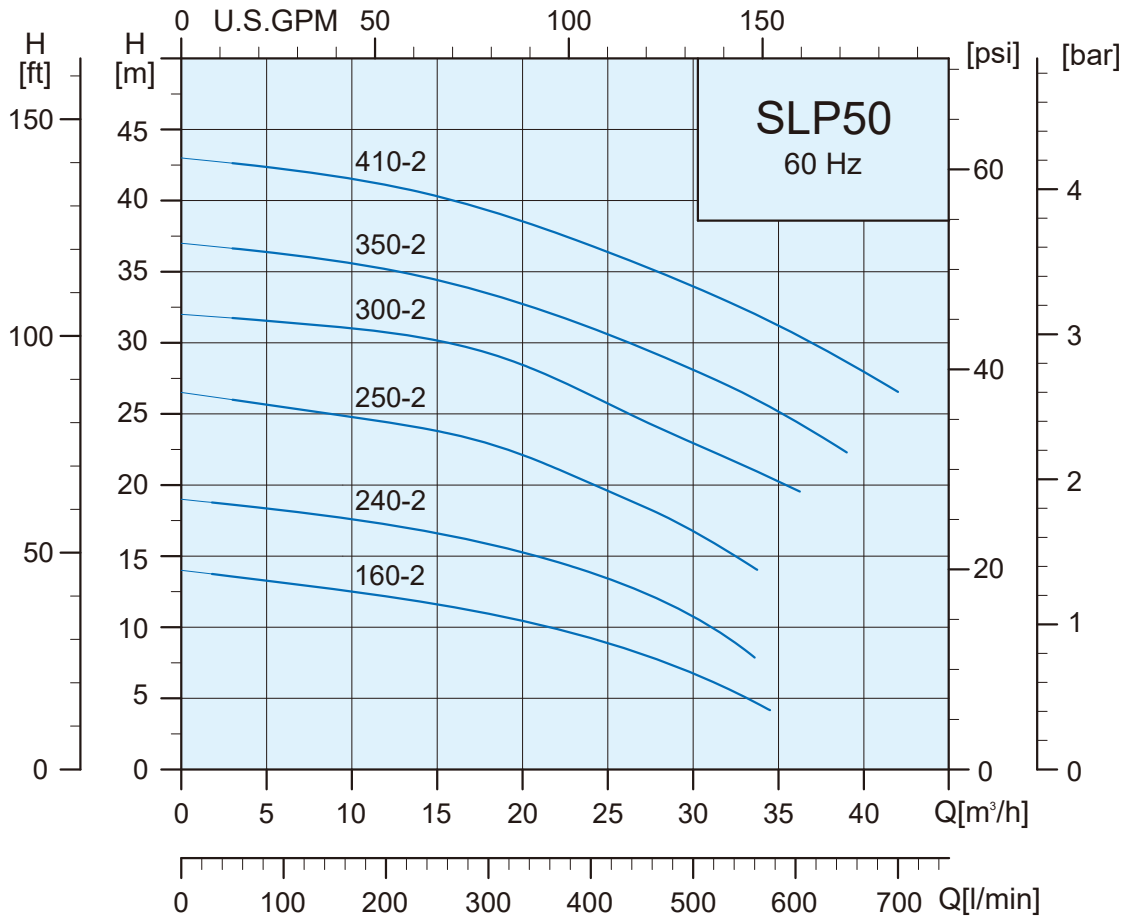

### Specifications

Model	Power		Head (Pressure)		Flow (Capacity)	Connection	T <sub>min</sub> / T <sub>max</sub>
	P <sub>2</sub>		Rated(m)	Max.(m)	Rated(m <sup>3</sup> /h)	Inlet / Outlet	°C
	kW	HP					
SLP 50-160-2	1.1	1.5	10.2	14.0	20.9	DN50	-25 / 120
SLP 50-240-2	1.5	2.0	14.6	19.0	22.0	DN50	-25 / 120
SLP 50-250-2	2.2	3.0	19.7	26.0	24.8	DN50	-25 / 120
SLP 50-300-2	3.0	4.0	24.3	32.0	27.5	DN50	-25 / 120
SLP 50-350-2	4.0	5.5	28.1	37.0	30.0	DN50	-25 / 120
SLP 50-410-2	5.5	7.5	32.6	43.0	32.6	DN50	-25 / 120

### Dimensions and Weights

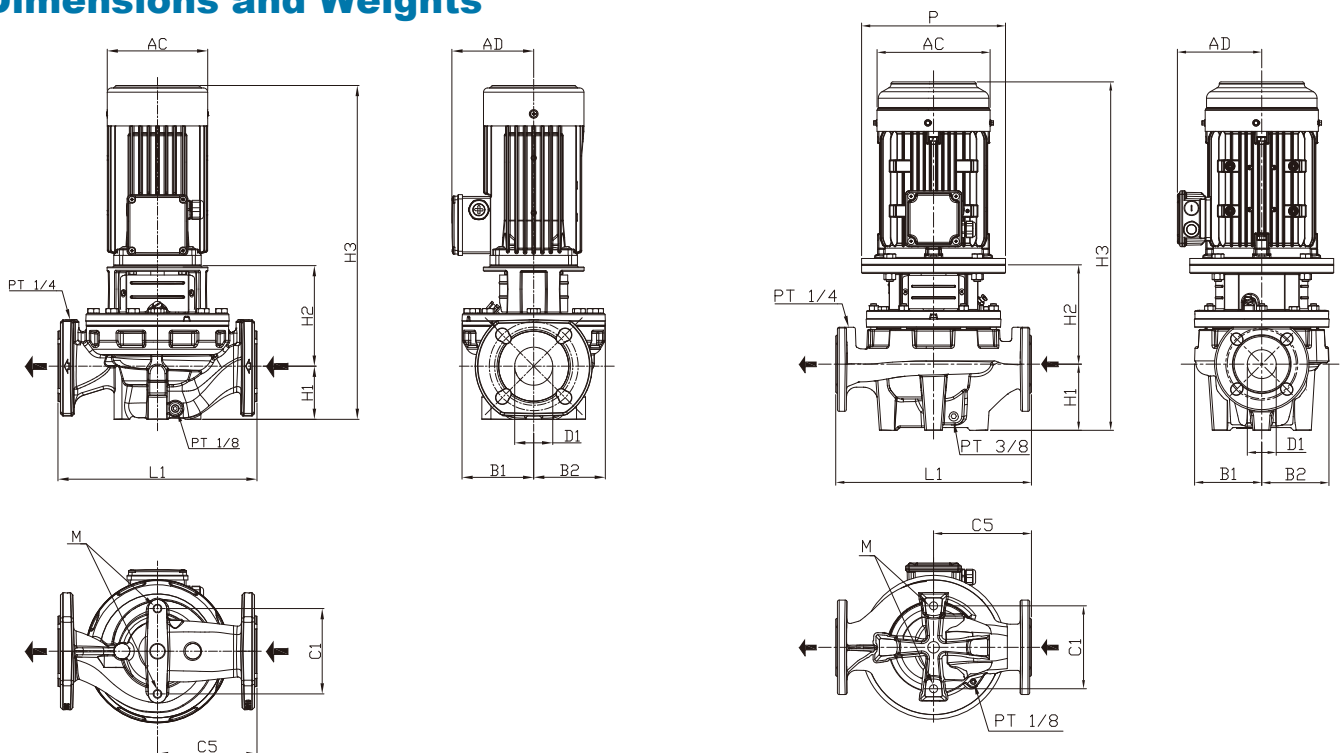

Model	Series	Flange		Dimension(mm)													Net Weight (kg)
		DIN	JIS	D1	AC	AD	P	B1	B2	C1	C5	L1	H1	H2	H3	M	
SLP 50-160-2	200	PN 6/10	10K	50	141	115	—	101	101	120	140	280	75	142	470	M12	28
SLP 50-240-2	200	PN 6/10	10K	50	177	141	—	101	101	120	140	280	75	151	523	M12	35
SLP 50-250-2	300	PN 16	10K	50	177	141	200	117	117	144	170	340	115	155	567	M16	57
SLP 50-300-2	300	PN 16	10K	50	197	147	250	117	117	144	170	340	115	173	606	M16	65
SLP 50-350-2	300	PN 16	10K	50	220	161	250	134	121	144	170	340	115	182	622	M16	72
SLP 50-410-2	300	PN 16	10K	50	235	197	300	134	121	144	170	340	115	201	678	M16	89

Performance Curves

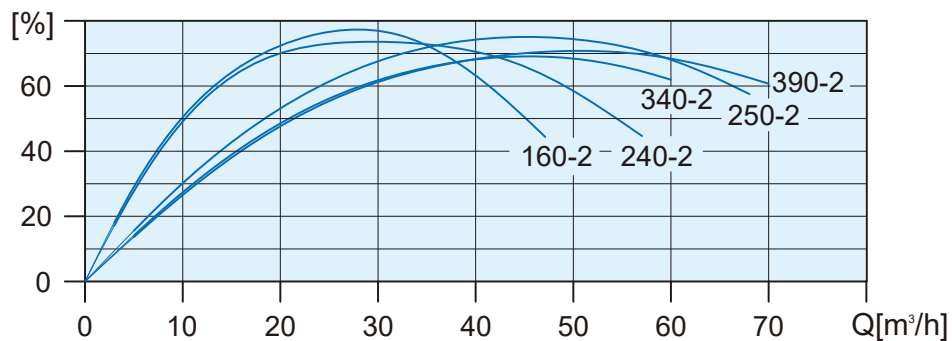
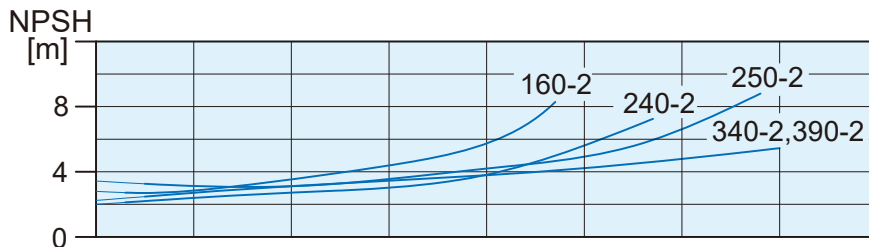
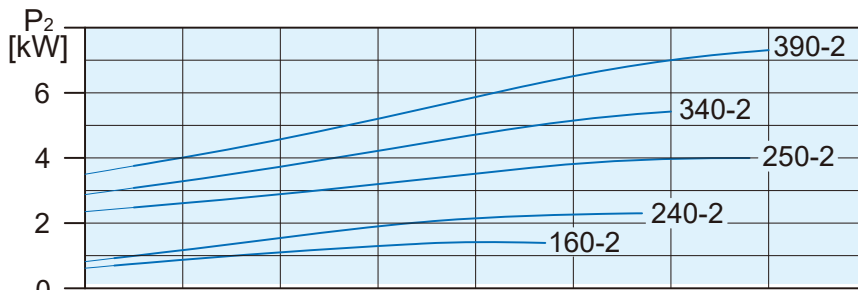
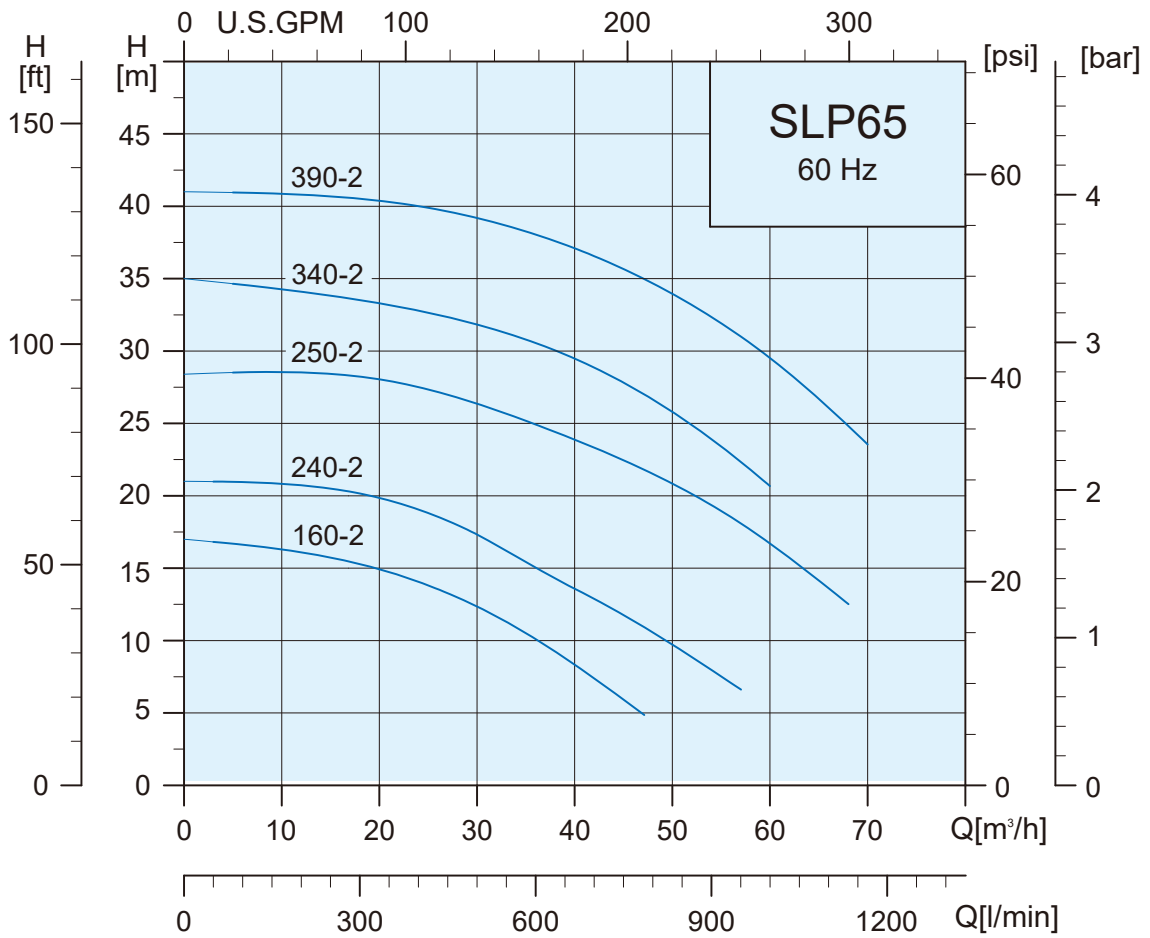

### Specifications

Model	Power		Head (Pressure)		Flow (Capacity)	Connection	T <sub>min</sub> / T <sub>max</sub>
	P <sub>2</sub>		Rated(m)	Max.(m)			
	kW	HP			°C		
SLP 65-160-2	1.5	2.0	11.9	17.0	31.2	DN65	-25 / 120
SLP 65-240-2	2.2	3.0	15.6	21.0	34.5	DN65	-25 / 120
SLP 65-250-2	4.0	5.5	19.9	28.0	52.5	DN65	-25 / 120
SLP 65-340-2	5.5	7.5	26.9	35.0	47.3	DN65	-25 / 120
SLP 65-390-2	7.5	10.0	33.4	41.0	51.6	DN65	-25 / 120

### Dimensions and Weights

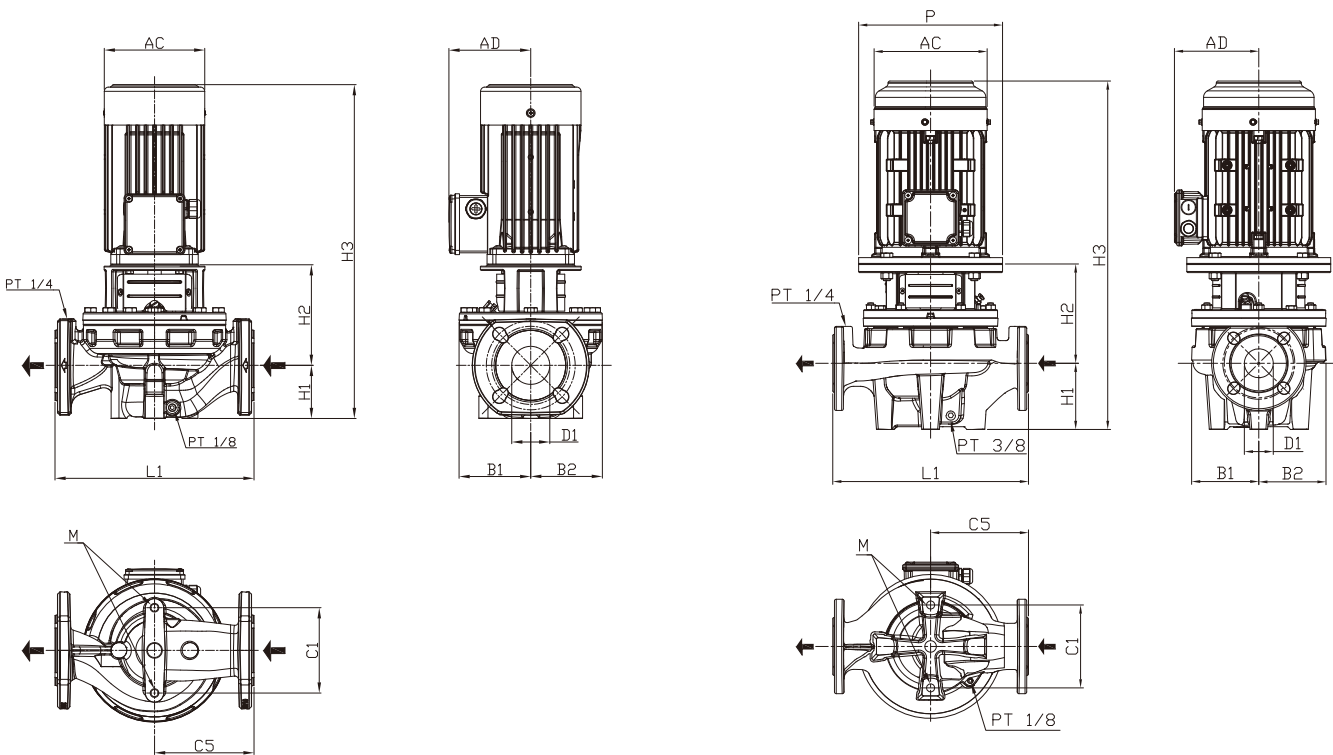

Model	Series	Flange		Dimension (mm)													Net Weight (kg)
		DIN	JIS	D1	AC	AD	P	B1	B2	C1	C5	L1	H1	H2	H3	M	
SLP 65-160-2	200	PN 6/10	10K	65	177	141	—	100	100	120	170	340	82	160	537	M12	40
SLP 65-240-2	200	PN 6/10	10K	65	177	141	—	100	100	120	170	340	82	160	537	M12	43
SLP 65-250-2	300	PN 16	10K	65	220	161	250	135	110	144	180	360	105	185	616	M16	74
SLP 65-340-2	300	PN 16	10K	65	235	197	300	142	123	144	180	360	105	212	679	M16	92
SLP 65-390-2	300	PN 16	10K	65	235	197	300	142	123	144	180	360	105	212	722	M16	98

Performance Curves

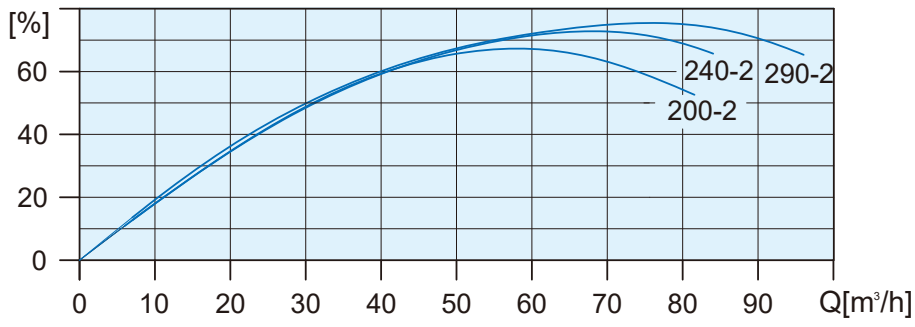
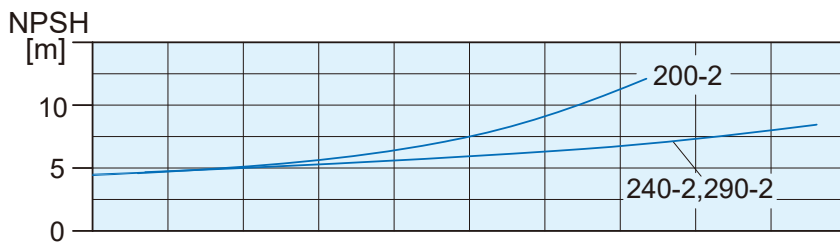
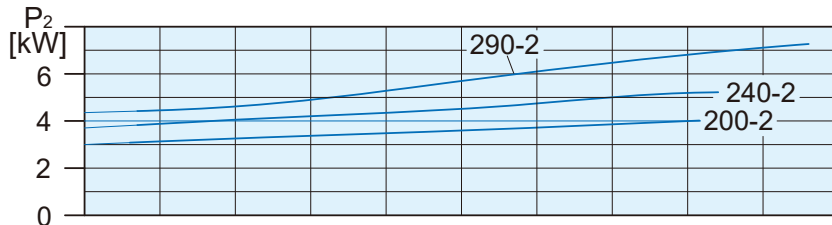
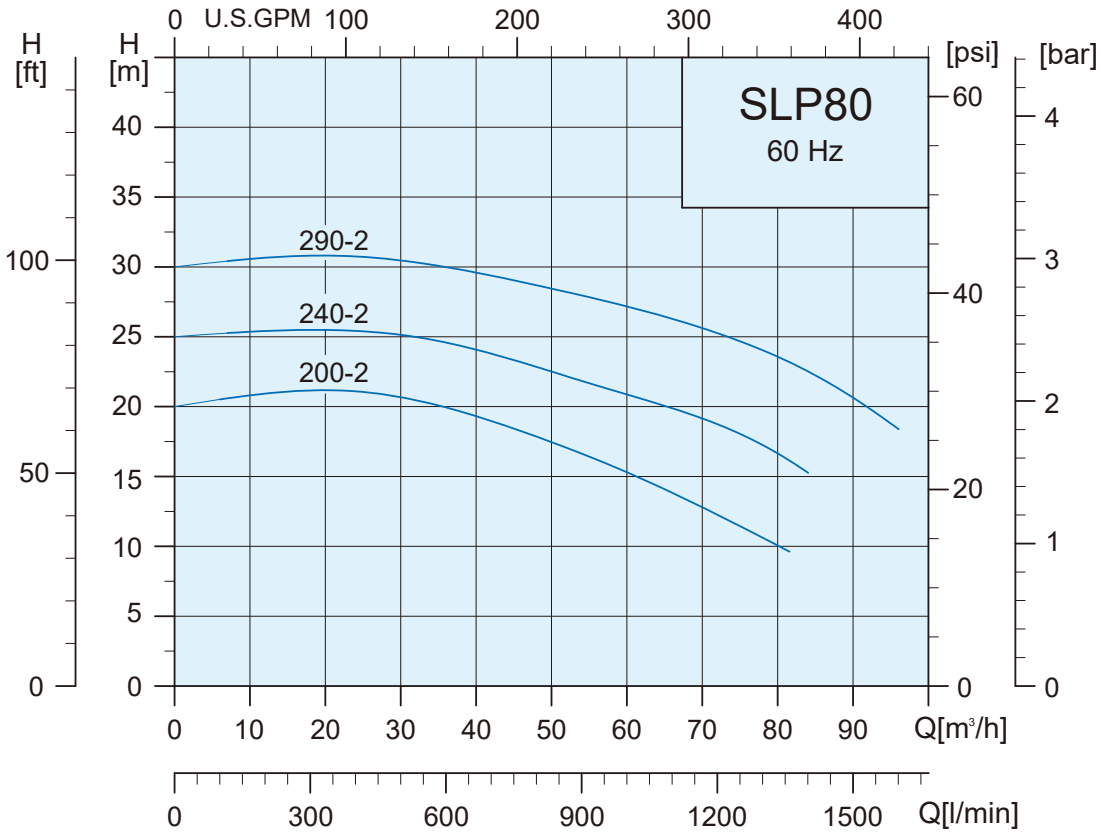



Performance Curves

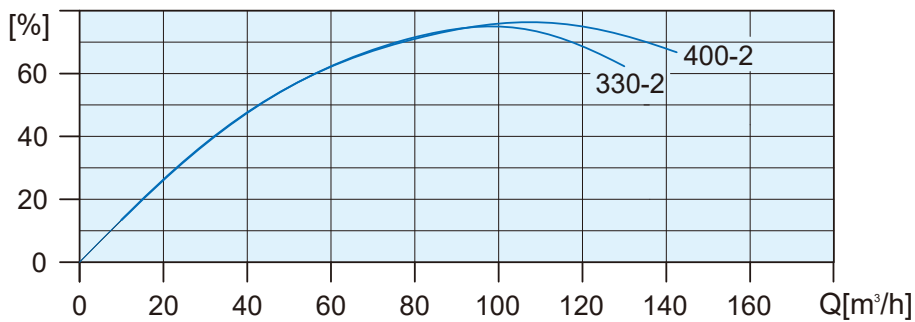
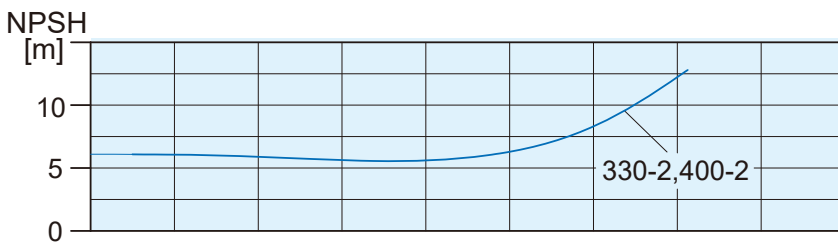
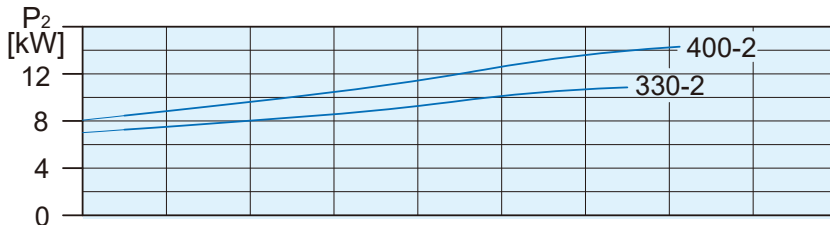
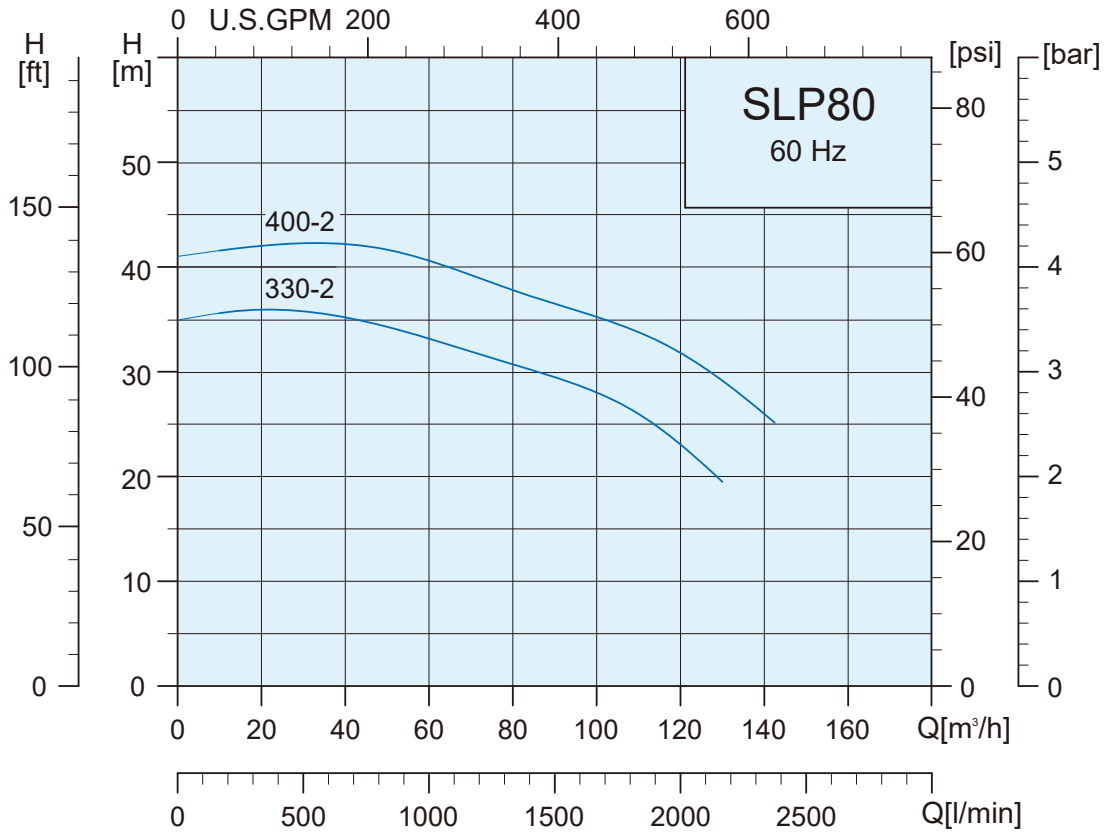

### Specifications

Model	Power		Head (Pressure)		Flow (Capacity)	Connection	T <sub>min</sub> / T <sub>max</sub>
	P <sub>2</sub>		Rated(m)	Max.(m)			
	kW	HP			°C		
SLP 80-200-2	4.0	5.5	14.9	20.0	61.9	DN80	-25 / 120
SLP 80-240-2	5.5	7.5	19.5	25.0	68.5	DN80	-25 / 120
SLP 80-290-2	7.5	10.0	25.0	30.0	75.7	DN80	-25 / 120
SLP 80-330-2	11.0	15.0	27.6	35.0	101.0	DN80	-25 / 120
SLP 80-400-2	15.0	20.0	33.3	41.0	112.0	DN80	-25 / 120

### Dimensions and Weights

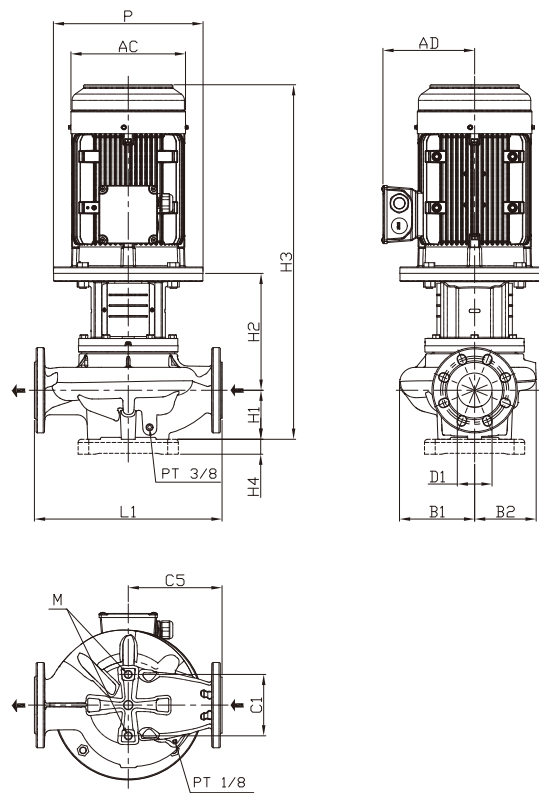

Model	Series	Flange		Dimension (mm)														Net Weight (kg)
		DIN	JIS	D1	AC	AD	P	B1	B2	C1	C5	L1	H1	H2	H3	H4	M	
SLP 80-200-2	300	PN 16	10K	80	220	161	250	135	123	144	180	360	105	197	627	—	M16	77
SLP 80-240-2	300	PN 16	10K	80	235	197	300	135	123	144	180	360	105	216	683	—	M16	95
SLP 80-290-2	300	PN 16	10K	80	235	197	300	135	123	144	180	360	105	216	726	—	M16	101
SLP 80-330-2	300	PN 16	10K	80	269	215	350	147	176	144	220	440	115	274	832	35	M16	146
SLP 80-400-2	300	PN 16	10K	80	269	215	350	147	176	144	220	440	115	274	876	35	M16	160